

SECTION

4



Inch Scale Dial Indicators

- Dial Gages
- Dial Gages (Metric)
- Pic Test Indicators
- Dial Bore Gage Sets
- Dial Thickness Gage

4

METROLOGY

Dial Gages

0.001"

- Easy-reading distinct graduations.
- Inch models have standard black needles and white dial faces or new high visibility orange needles and black faces. Metric models have yellow dial faces. (see page 72)
- Hard, satin-chrome finish.
- Superior quality of spindle rack, pinions and gear trains ensure longevity.
- Meets or exceeds applicable US federal specifications.
- Conforms to AGD specifications.

Dimensions

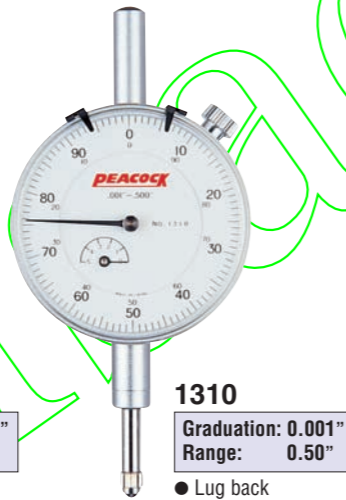
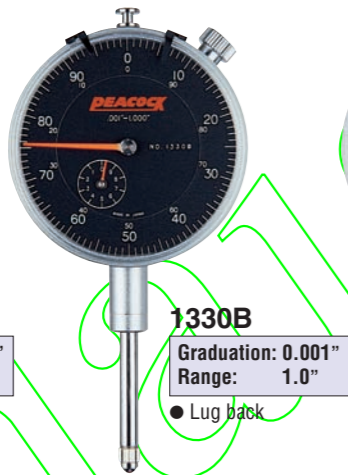
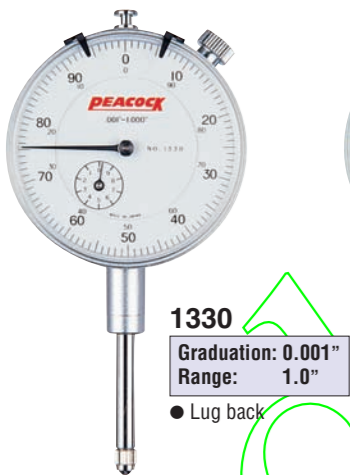
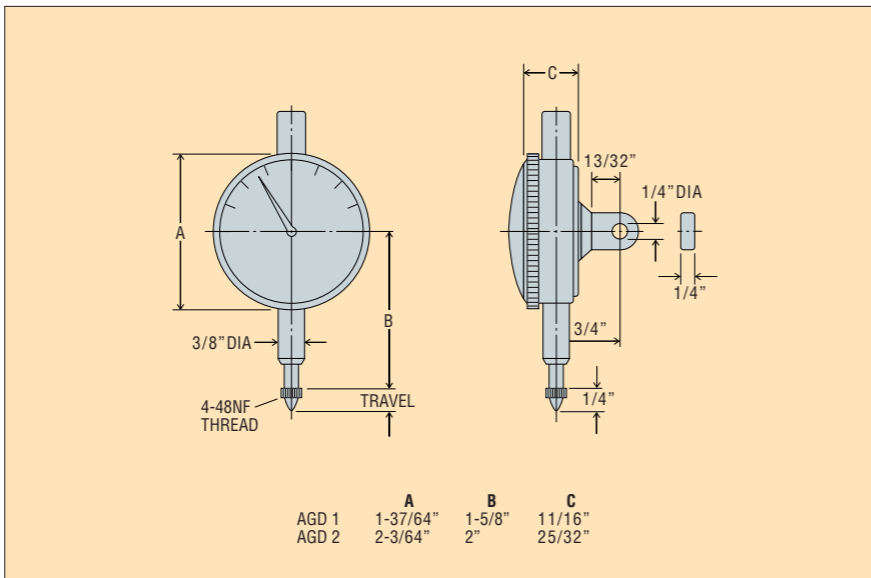

0.001"



0.0001"

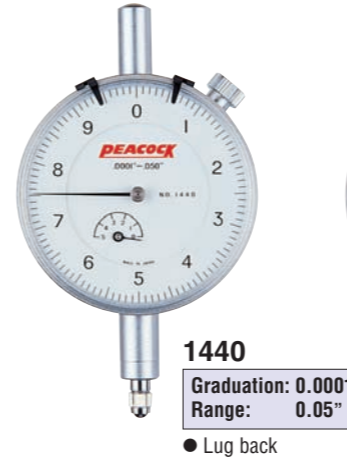

Specifications

White face Model No.	Black face Model No.	Measuring range	Graduation	Reading	Wide range forward accuracy	Retrace error	Measuring force (less than)	Back Config.	AGD
1200		.20"	.001"	±0-50-100	.0008"	.0003"	1.4N	Lug	1
1330	1330B	1.0"	.001"	±0-50-100	.002"	.0004"	2.0N	Lug	2
1310	1310B	.50"	.001"	±0-50-100	.001"	.0003"	1.8N	Lug	2
1364	1364B	2.0"	.001"	±0-50-100	.004"	.0004"	2.5N	Lug	2
1440	1440B	.05"	.0001"	±0-5-10	.0003"	.0002"	1.5N	Lug	2
1460	1460B	.05"	.0001"	0-5-0	.0003"	.0002"	1.5N	Flat	2

Inch Scale Dial Indicators

Inch Scale Dial Indicators

4 Metric Graduations 0.01mm

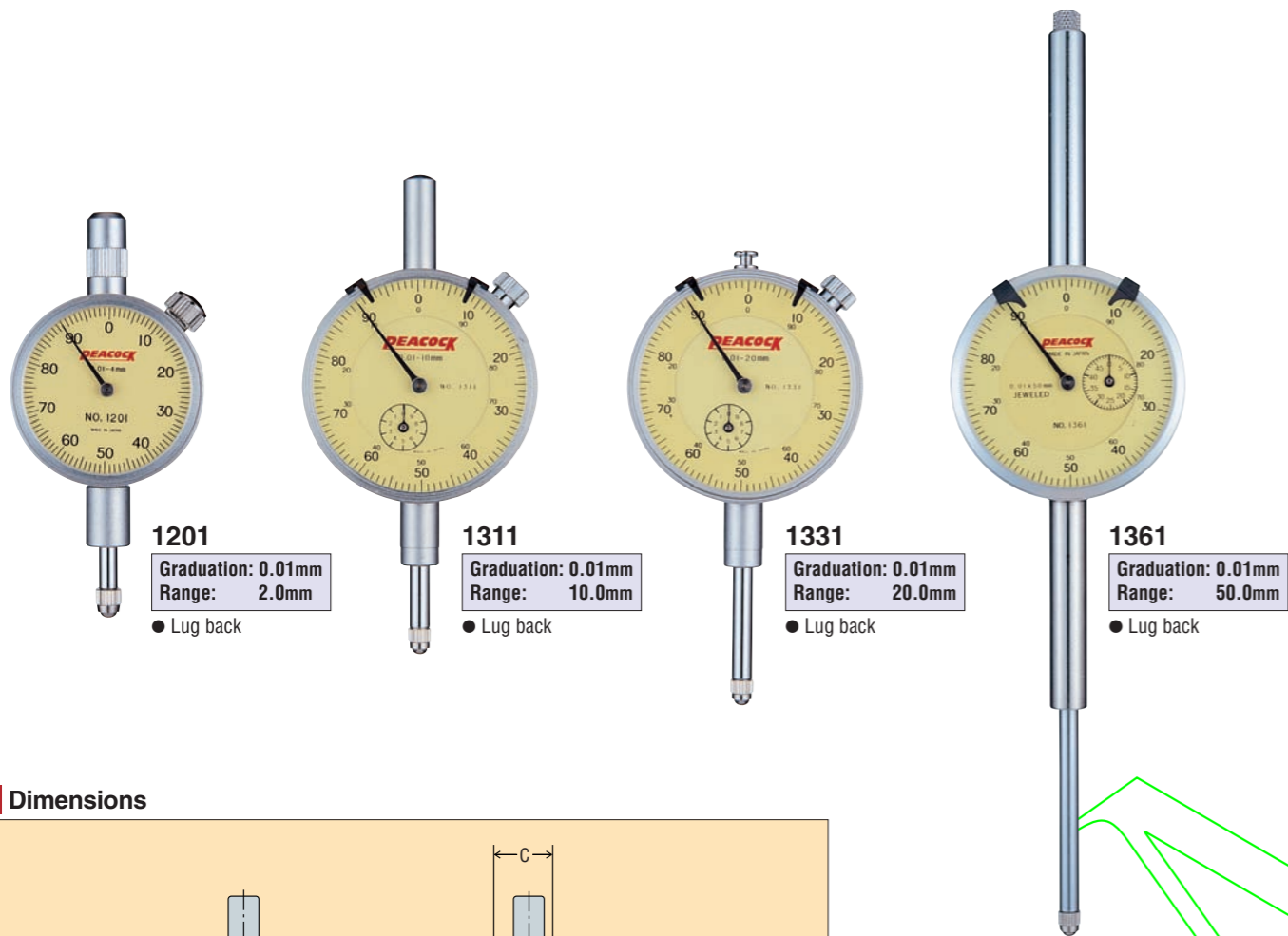

1201
Graduation: 0.01mm
Range: 2.0mm
● Lug back

1311
Graduation: 0.01mm
Range: 10.0mm
● Lug back

1331
Graduation: 0.01mm
Range: 20.0mm
● Lug back

1361
Graduation: 0.01mm
Range: 50.0mm
● Lug back

Dimensions

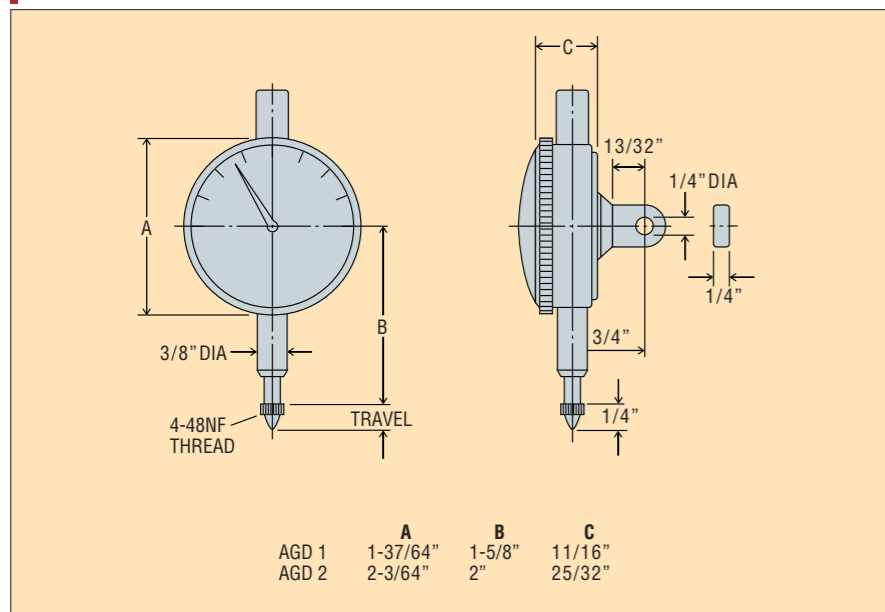

Specifications

Model No.	Measuring range	Graduation	Reading	Wide range forward accuracy	Retrace error	Measuring force (less than)	Back Config.	AGD
1201	4.0mm	0.01mm	±0-50-100	12 μm	3 μm	1.4N	Lug	1
1311	10.0mm	0.01mm	±0-50-100	15 μm	3 μm	1.4N	Lug	2
1331	20.0mm	0.01mm	±0-50-100	25 μm	4 μm	2.2N	Lug	2
1361	50.0mm	0.01mm	±0-50-100	50 μm	5 μm	2.5N	Lug	2

Pic Test Indicators

- Auto-reversing.
- Comes complete with .038", .078", .125" dia hardchromed contact points, Clamping bars, wrench and three stems: 3/8", 1/4" and 5/32".
- 180° swing on point and shaft.
- Fully jeweled movements.
- White face models have black needles, numbers and graduations. Black face models have bright, fluorescent orange needles with white numbers and graduations.
- Dial diameter is 1-3/8".
- Universal positioning capability.
- Dovetails on top, back & front.
- Excellent rigid
- Non-magnetic

Horizontal Type

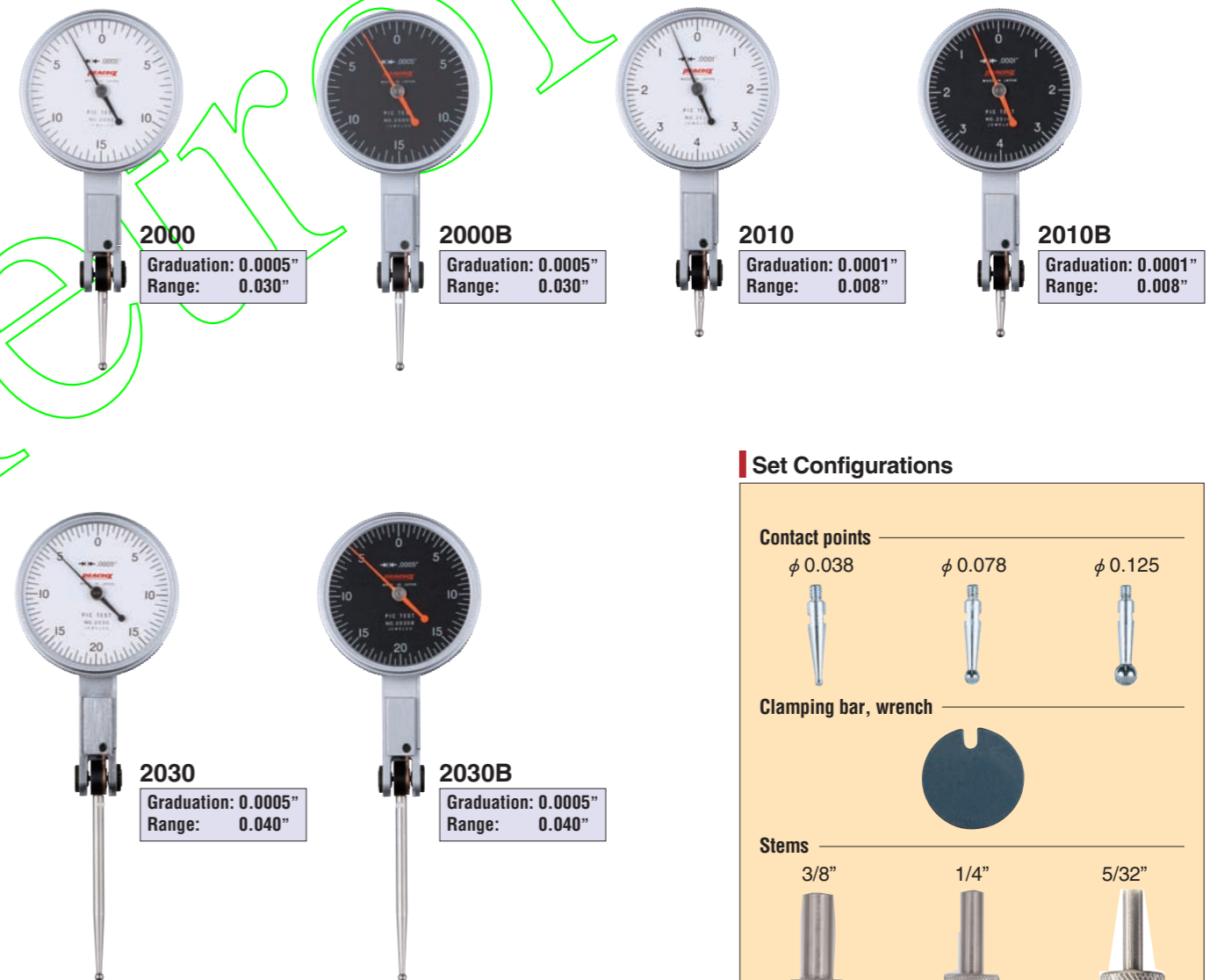

2000
Graduation: 0.0005"
Range: 0.030"

2000B
Graduation: 0.0005"
Range: 0.030"

2010
Graduation: 0.0001"
Range: 0.008"

2010B
Graduation: 0.0001"
Range: 0.008"

2030
Graduation: 0.0005"
Range: 0.040"

2030B
Graduation: 0.0005"
Range: 0.040"

Set Configurations

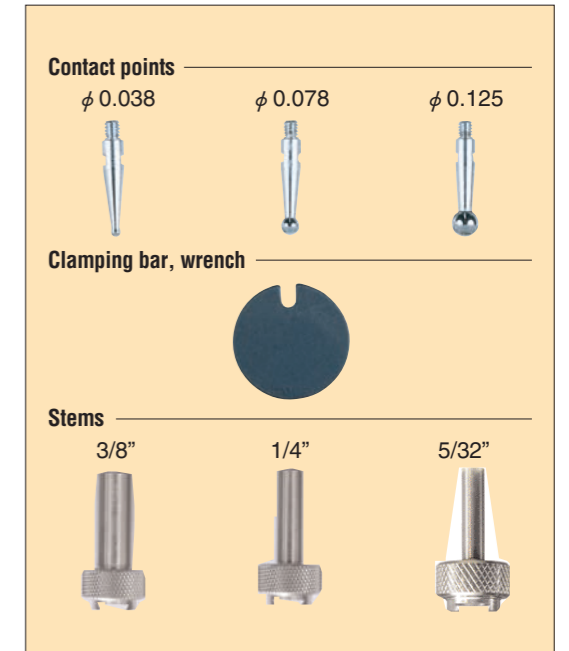

Specifications

White face Model No.	Black face Model No.	Measuring range	Graduation	Reading	Wide range forward accuracy	Backward error	Measuring force (less than)	Contact point length
2000	2000B	.030"	.0005"	0-15-0	.0005"	.0003"	0.3N	.750"
2010	2010B	.008"	.0001"	0-4-0	.0003"	.0002"	0.3N	.375"
2030	2030B	.040"	.0005"	0-20-0	.0010"	.0003"	0.3N	1.750"

Vertical Type

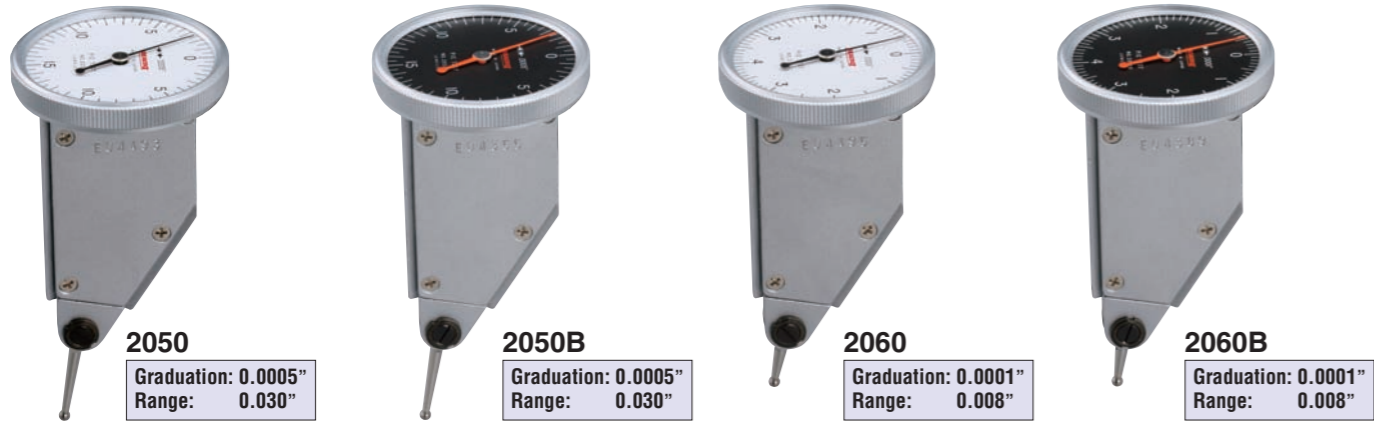

Large Size Dial Face Type

The dial plate size of 2200, 2200B, 2210, and 2210B models has been enlarged, with easy reading due to the larger scale spacing, as a result.



Set Configurations

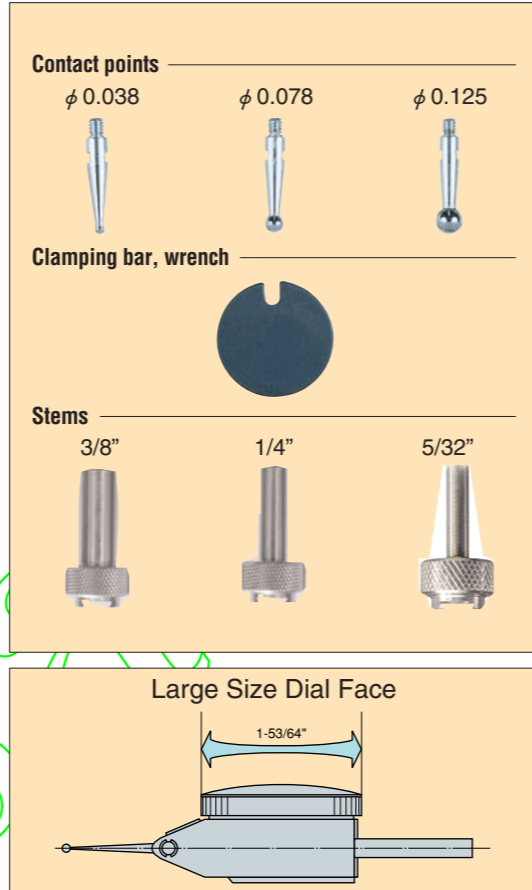

Specifications

White face Model No.	Black face Model No.	Measuring range	Graduation	Reading	Wide range forward accuracy	Backward error	Measuring force (less than)	Contact point length
2050	2050B	.030"	.0005"	0-15-0	.0005"	.0003"	0.3N	.750"
2060	2060B	.008"	.0001"	0-4-0	.0003"	.0002"	0.3N	.375"
2200	2200B	.030"	.0005"	0-15-0	.0005"	.0003"	0.3N	.750"
2210	2210B	.008"	.0001"	0-4-0	.0003"	.0002"	0.3N	.375"

Dial Bore Gage Sets

- Each set includes a high quality ADG2 Dial indicator with .0001" graduations. High precision, combined with ultra smooth movement, makes this the set for the most demanding users.
- Set comes complete with protective cover and fitted case.
- For close tolerance measurements of hole sizes, ID taper dimensions and roundness.
- Each set includes a reference chart, clearly specifying Spacer and Feeler sizes, for each measurement range.



5730 complete set



Specifications

White face Model No.	Black face Model No.	Range	Wide range accuracy	Adjacent error	Repeated error	Length below Grip	Number of Feeler	Number of Spacer
5710	5710B	.250-.400"	.0002"	.00008"	.00008"	1-31/32"	8	—
5730	5730B	.370-.750"	.0002"	.00008"	.00008"	3-15/16"	10	1
5740	5740B	.750-1.50"	.0002"	.00008"	.00008"	5-29/32"	8	2
5750	5750B	1.50-2.50"	.0002"	.00008"	.00008"	5-29/32"	6	2
5770	5770B	2.00-6.00"	.0002"	.00008"	.00008"	5-29/32"	11	2
5790	5790B	6.00-10.0"	.0002"	.00008"	.00008"	9-29/32"	9	4

Dial Thickness Gage

4

- Designed for quick and accurate measurement of small parts, sheet metal, paper, fabric, etc.
- Convenient, one-handed operation.
- Preloaded spindle for consistent measuring pressure.
- Adjustable zero setting with bezel.
- Baked enamel finish.
- Distinct, fine graduations for easy reading.
- Spindle made of hardened steel.



4600
Graduation: 0.001"
Range: 0.5"

Metrology

Specifications

Model No	Range	Graduation	Throat depth	Accuracy	Measuring force (less than)
4600	.50"	.001"	.78"	.0010"	1.8N



● For measuring thickness of paper