

SECTION

11



Digital Indicators

- Digital Dial Gauge
- Linear Gauge
- Digital Counter
- Application Series
- Deep Hole Bore Gauge
- Technical Glossary

metrology

Overview of Digital Gauges & Display Combinations

Display and Supporting Units

Measuring range	2mm	5mm	12.5mm	20(25)mm	50mm	100mm
Resolution						
0.01mm			DG-127	DG-257		
0.001 mm				DG-205	PDN-51 0.001mm (Convertible to 0.01mm)	
				PDN-21 0.001mm (Convertible to 0.01mm)		
0.01mm	DL-2 (Lever Type)	D-5	D-10 New DN-10	D-20 New DN-20	D-50	D-100
		D-5UZ				
0.001 mm	DL-2S (Lever Type)	D-5S	D-10S New DN-10S	D-20S New DN-20S	D-50S	D-100S
0.0005 mm (0.5 μm)			D-10SS			
0.0001 mm (0.1 μm)			D-10HS			

Counter

C-500 (Simple function)



RS-232C →



C-700 (Multi-function)



CM-5B (Counter with Comparator)



C-500 (Simple function)



C-700 (Multi-function)



CM-5B (Counter with Comparator)



C-7HS (0.1μm Resolution)



Digital Indicators

Cordless Type

- The batteries in these digital indicators have a service life of approximately 3000 hours under normal use.
- Digital display can be rotated (approx. 270°) to easily legible positions.
- Very compact, and long 25mm stroke. (DG-257, DG-205)
- RS-232C data output capability.
- No warm-up required. Switch on, and it's immediately ready to use.
- Clear LCD display.



DG-127
Resolution: 0.01mm
Range: 0~12.5mm

DG-257
Resolution: 0.01mm
Range: 0~25mm

DG-205
Resolution: 0.001mm
Range: 0~25mm

Specifications

Model	DG-127	DG-257	DG-205
Range	12.5mm	25mm	
Resolution	0.01mm		0.001mm
Accuracy (excluding quantized error)	0.01mm		0.003mm
Display (LCD display)	5 digit -999.99 with (-) symbol		6 digit -999.999 with (-) symbol
Measuring force (when correctly positioned)	Less than 0.95N	Less than 1.1N	
Operating temperature	+5~40°C		
Battery	One CR2032 type lithium battery (included)		
Data output	RS-232C port (opto-cable sold separately)		
Mounting method	Supported by ϕ 8mm stem, (Lug back, GB-1205 is optional)		
Contact point	M2.5 x 0.45 Thread with carbide ball (XB-1)		
Weight	230g		
Functions	<ul style="list-style-type: none"> ● ZERO RESET-----Resetting to zero at any desired position ● PRESET-----Preset at a desired value ● DATA HOLD-----Data can be held for direct data output to outside computer ● MM/INCH-----Easily switch between metric and inch systems ● Low battery warning display-----"B" signifies low battery (Battery dies within 2~3 hours after "B" is first displayed) ● Display rotation-----Display can be rotated up to 270° for easy reading ● Counting direction conversion-----Plus and minus directions, for spindle movement, can be selected. 		

Dimensions (DG-205/DG-257/DG-127)

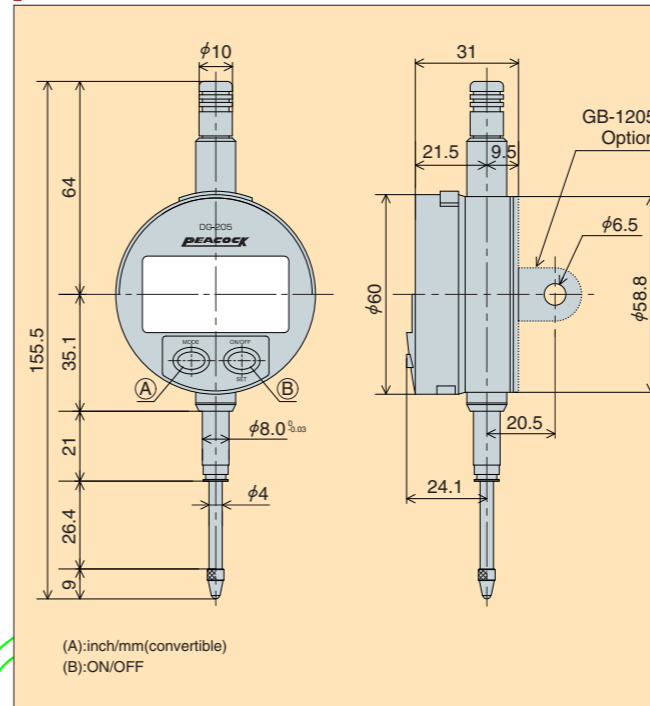

Example of Connection

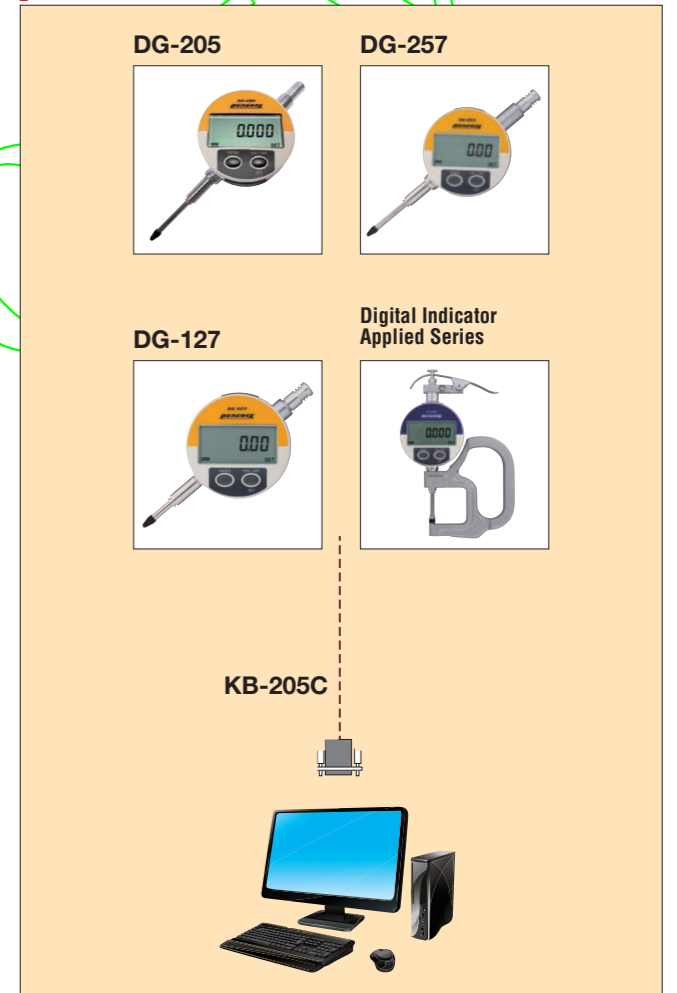

Optional accessories

<p>Lug Back GB-1205</p>	<p>Opto-cable KB-205C</p> <p>For direct RS-232C connection to your PC.</p>	<p>Opto-cable KB-205USB</p> <p>Connecting cable for PC (USB type)</p>
--------------------------------	---	--

<p>Lifting Lever LL-205</p> <p>Lifting range (0~25mm)</p>	<p>Release RE-205</p> <p>Lifting range (0~12mm)</p>
--	--

Linear Gauges

Measurement range(0~5mm)

Lever Type

- Best suited for deviation measurement.



DL-2

Resolution: 0.01mm
Range: 0~2mm

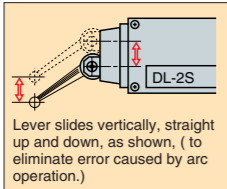

DL-2S

Resolution: 0.001mm
Range: 0~2mm

Lever slides vertically, straight up and down, as shown, (to eliminate error caused by arc operation.)

Pencil Type

- Best suited for confined conditions.



D-5

Resolution: 0.01mm
Range: 0~5mm

D-5S

Resolution: 0.001mm
Range: 0~5mm

Contact Point (X-2)

Small Type

- Best suited for work in confined space measurement.



D-5UZ

Resolution: 0.01mm
Range: 0~5mm

Contact Point (X-107)

Specifications

Model	DL-2	DL-2S	D-5	D-5S	D-5UZ	
Range	※ 2mm		5mm		5mm	
Resolution	0.01mm	0.001mm	0.01mm	0.001mm	0.01mm	
Accuracy (excluding quantized error)	0.01mm	0.002mm	0.005mm	0.002mm	0.01mm	
Measuring force	Less than 0.6N		Less than 0.5N		Less than 1.0N	
Mounting method	φ 6.5mm hole on lug or dovetail at bottom		φ 8mm stem		φ 6.5mm hole on lug back	
Contact point	S φ 2mm carbide		S φ 2.4mm steel (X-2)		S φ 2.4mm steel (X-107)	
Weight	180g		160g		200g	
Cable length	2m (Standard)		Option ● Extension cables of 2, 3, 5 and 10 meters are available (see page P.143)			
Operating temperature	0~40°C					
Output signal	90° phase difference, 20μm pitch (R03-PB8M Tajimi connector)					
Features	<ul style="list-style-type: none"> ● Lever type probe is best recommended for measuring TIR or narrow space. ● Contact point easy adjustable to any desired position. 	<ul style="list-style-type: none"> ● Pencil type is especially made for setting up in extremely confined conditions. ● Dust proof rubber attached. Gauge suitable for use in dusty and moist environment. 	<ul style="list-style-type: none"> ● The gauge height is extremely short to fit in limited spaces. ● Set by lug on the back of the gauge (φ 6.5mm hole) 			
Compatible standard counters	C-500 C-700 CM-5B					
Options			<ul style="list-style-type: none"> ● Customer must specify if application is up-side-down. The measuring force changes when the gauge is inverted. 		<ul style="list-style-type: none"> ● Replaceable Contact Point XS-6 ● Other Optional Contact Points 	

※ Lever moves linearly, unlike the arc movement in a lever type dial indicator.

Dimensions

DL-2/DL-2S

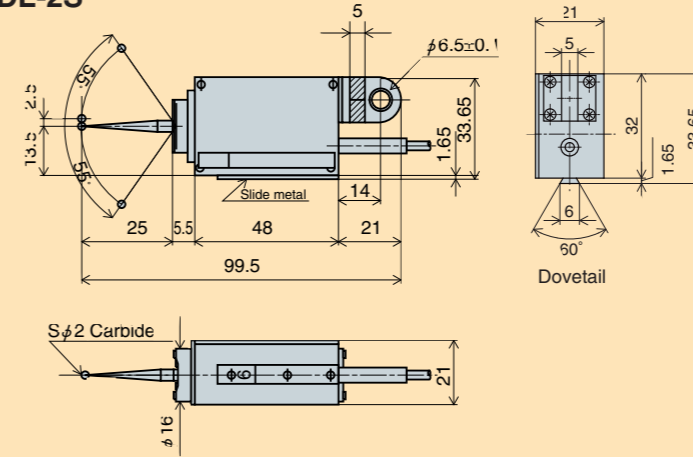

D-5/D-5S

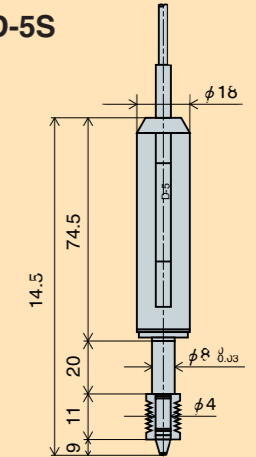

D-5UZ

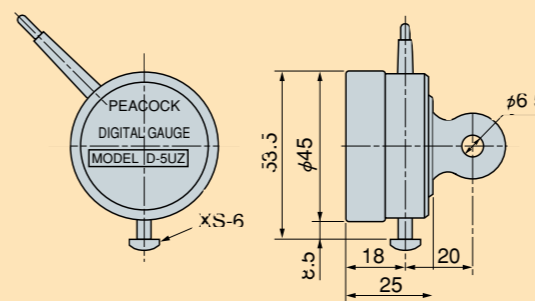

Examples

- Testing TIR (Total Indicator Run-out) of a cylinder

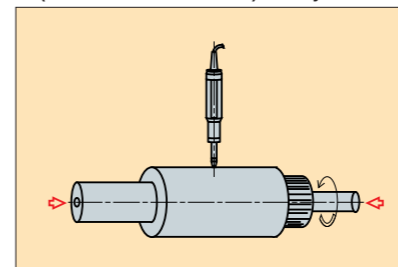

- Multi-point testing of a thick board

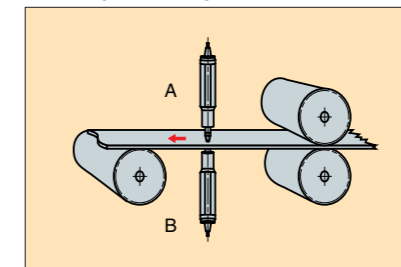

- Internal surface measurement of a cylinder

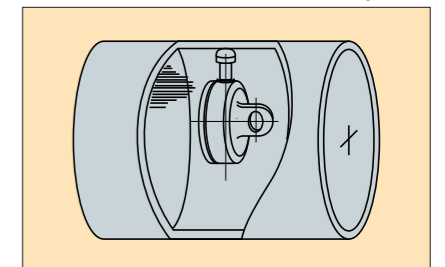

- Measuring Angles

Gauges are set at position X and Y and the difference between them is converted into angle for judgement. (In this example, the left angle of a golf club is measured and printed out)

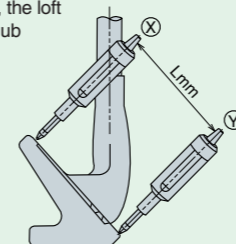

- Multi-Point Measuring

Mount the same number of linear gauges to measure the numbers of points where measurement is needed. Measured data is processed by a multi-counter with CPU and printed out on a printer.

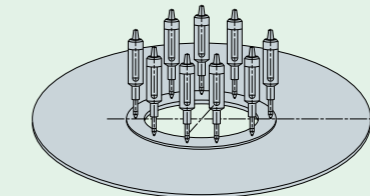

- Measuring Glass Tubes

Outer diameter, thickness, and thickness variation of glass tubes such as fluorescent tubes are measured and displayed. Built-in printer prints out the measured data.

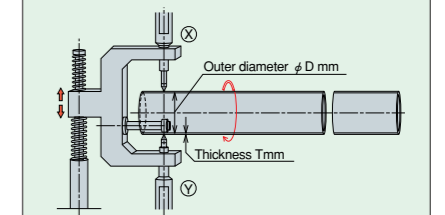

Measurement range (0~10mm, 0~20mm)

- 10mm and 20mm measurement ranges are the easiest to use.
- Used in conjunction with digital counters, these gauges can be set up in places where dial gauges are now being used.
- Set the gauge by either stem or lug back.
- For lifting spindle, both lever and release types are available.

Rectangular wave output type

DN-10 • DN-10S • DN-20 • DN-20S

- For use in electrically noisy environments.
- For applications requiring extra long cables. (10 to 50 meters are available)

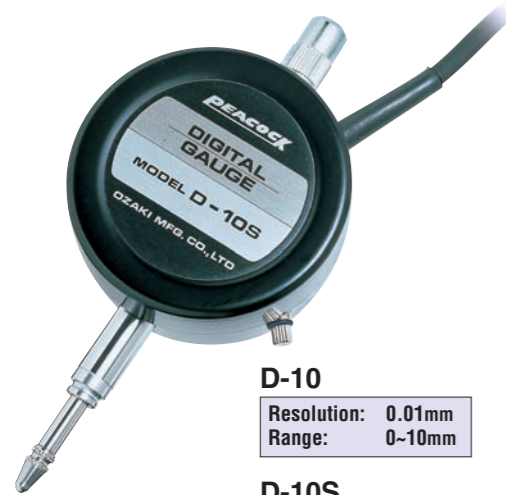

D-10
Resolution: 0.01mm
Range: 0~10mm



DN-10 New
Resolution: 0.01mm
Range: 0~10mm



DN-20 New
Resolution: 0.01mm
Range: 0~20mm

D-10S
Resolution: 0.001mm
Range: 0~10mm

DN-10S New
Resolution: 0.001mm
Range: 0~10mm

DN-20S New
Resolution: 0.001mm
Range: 0~20mm

Output wave-form (DN-10 • DN-20)

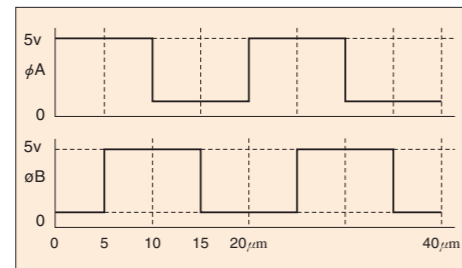

Output wave-form (DN-10S • DN-20S)

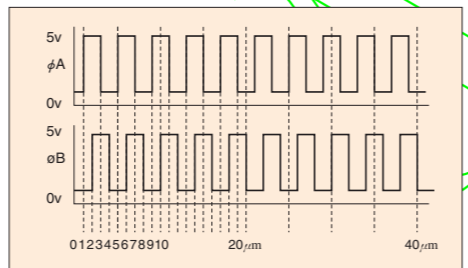

Dimensions (D-10 / D-10S / D-10SS / D-20 / D-20S / DN-10 / DN-10S / DN-20 / DN-20S)

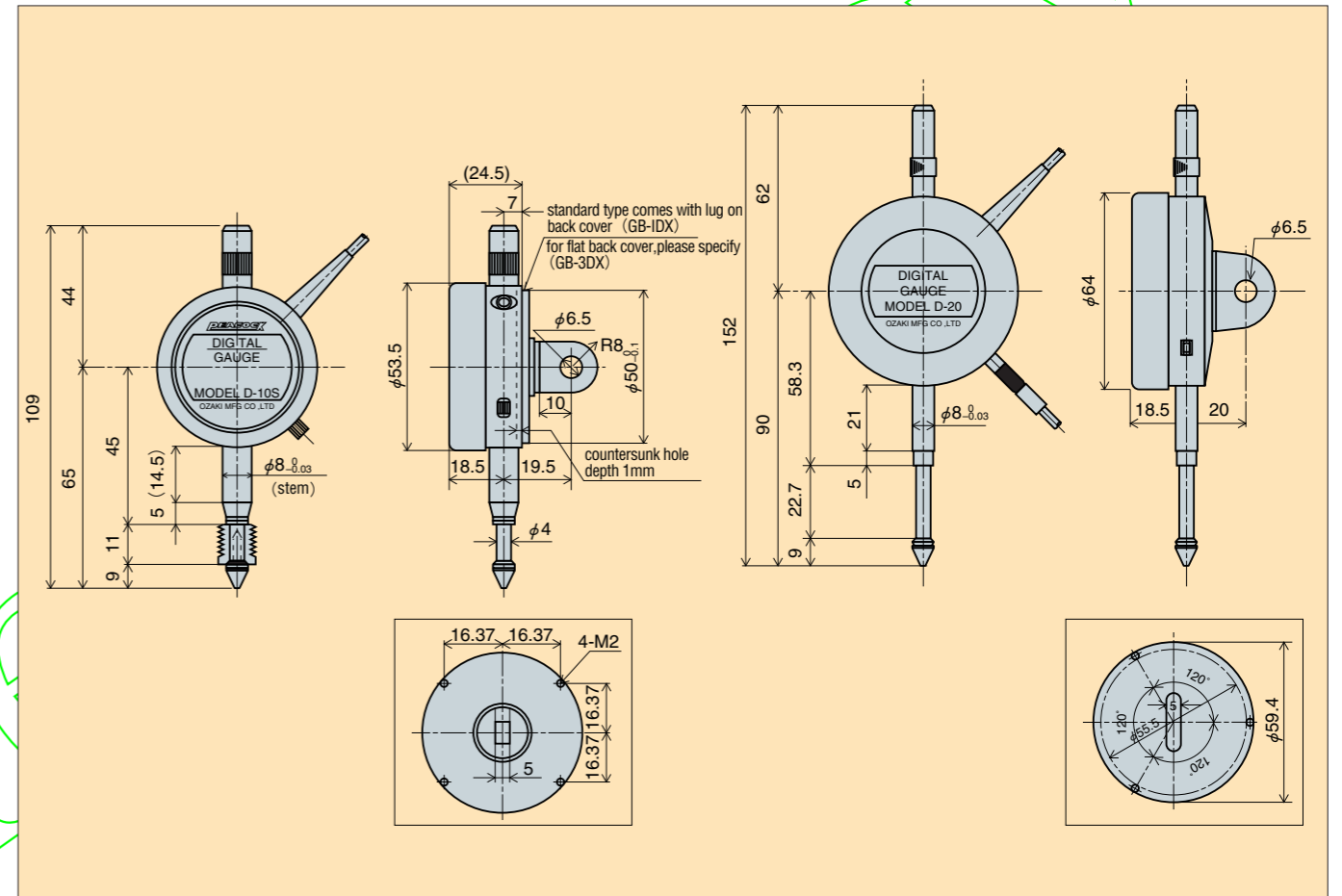

Specifications

Model	D-10	D-10S	DN-10	DN-10S	D-20	D-20S	DN-20	DN-20S
Range	10mm				20mm			
Resolution	0.01mm	0.001mm	0.01mm	0.001mm	0.01mm	0.001mm	0.01mm	0.001mm
Accuracy (excluding quantized error)	0.005mm	0.002mm	0.01mm	0.002mm	0.005mm	0.003mm	0.01mm	0.003mm
Measuring force	Less than 1.0N				Less than 1.5N			
Cable length	2m							
Mounting method	φ 8mm stem or 6.5mm hole on lug back							
Contact point	M2.5 × 0.45 S φ 2.4mm steel (X-2)							
Operating temperature	0~40°C							
Weight	220g				300g			
Output Signal	90° phase difference, 20μm pitch (R03-PB8M Tajimi connector) Rectangular wave (Low=0V High=8V)							
Compatible standard counters	C-500 C-700 CM-5B (*except DN-10S, DN-20S)							
Options	<ul style="list-style-type: none"> ● Release (RE-4) Lifting lever (LL-1) ● Dust proof rubber (BG-10) ● Flat back (GB3-D10), screws (S-110) ● Customer must specify if application is up-side-down. The measuring force changes when the gauge is inverted.				<ul style="list-style-type: none"> ● Release (RE-4) ● Flat back (GB3-D20) ● Customer must specify if application is up-side-down. The measuring force changes when the gauge is inverted.			

*Features
 DN-10 DN-10S DN-20 DN-20S
 ●1 Recommended for locations where cable extension (10 to 50 meters) is necessary.
 ●2 Recommended for use in electrically noisy environments.
 Notes of wiring : A signal wire should be duct wiring apart from other power lines.

Options

Split collar (WB-1)

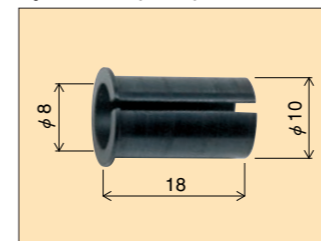

Split collar above is used on the φ 8mm stem during mounting to prevent malfunction due over tightening.
 Securing by means of screw directly in stem may result in malfunction.

Dust proof rubber (BG-10)



Compressible dust proof rubber fits all D-5, D-5S, D-10S, D-10SS, DN-10, DN-10S gauges. (Stroke under 10mm)

Release (RE-4)



Total length 305mm

Lifting lever (LL-1)



Measurement Range (0~50mm, 0~100mm)

- With very sturdy $\phi 20$ mm stem.
- Ultra-high precision achievable with exclusive gauge stand (PDS-2)

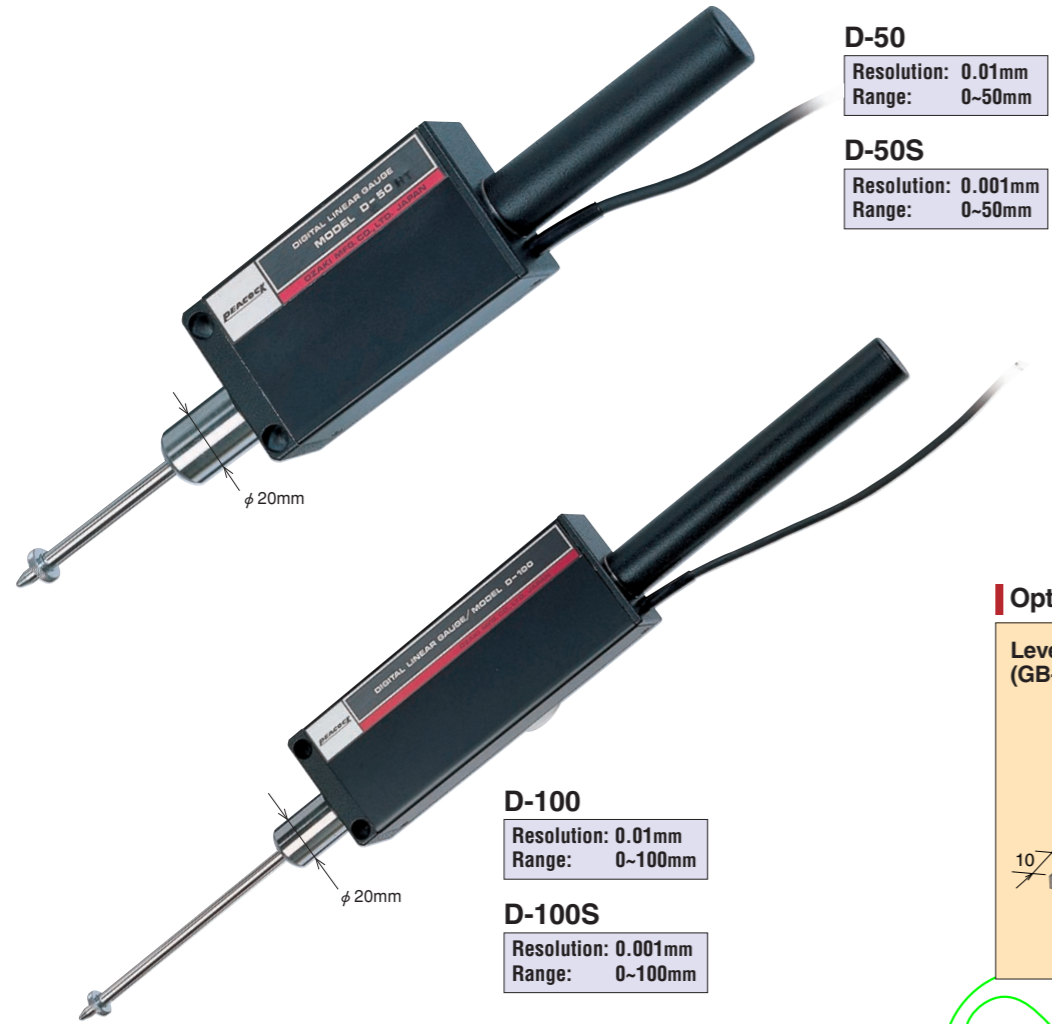

D-50
Resolution: 0.01mm
Range: 0~50mm

D-50S
Resolution: 0.001mm
Range: 0~50mm

D-100
Resolution: 0.01mm
Range: 0~100mm

D-100S
Resolution: 0.001mm
Range: 0~100mm

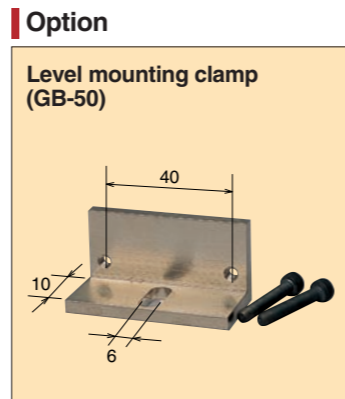

Specifications

Model	D-50	D-50S	D-100	D-100S
Range	50mm		100mm	
Resolution	0.01mm	0.001mm	0.01mm	0.001mm
Accuracy (excluding quantized error)	0.01mm	0.004mm	0.01mm	0.005mm
Measuring force	Less than 3.0N		Less than 3.5N	
Cable length	2m			
Mounting method	$\phi 20$ mm stem or fastening by M4 screws at two positions			
Contact point	M2.5 \times 0.45 S $\phi 2.4$ mm steel (X-9)			
Operating temperature	0~40°C			
Weight	450g		520g	
Output signal	90° phase difference, 20 μ m pitch (R03-PB8M Tajimi connector)			
Compatible standard counters	C-500 C-700 CM-5B			
Accessories	● Finger lever for lifting spindle (LL-D50)1 pc			
Features	● If Spindle inner spring is removed, measuring force will be that of spindle itself (only when in upright position) ● D-50, D-50S1.0N (100gf) D-100, D-100S1.1N (110gf) ● Recommended Gauge stand is PDS-2			
Option	● Level mounting clamp (GB-50) see page 141 ● Customer must specify if application is up-side-down. The measuring force changes when the gauge is inverted.			

Special Gauges

For High Temperature Applications D-50HT (0.01mm Resolution)



This special gauge can be used up to +65°C temperature. 0.01mm (0.005mm) Resolution (D-50S is not suited for high temperature)

For Dusty Applications D-50WA D-50SWA



Dust-proof rubber protects spindle. Equivalent to IP-54. (Protection against oil & water is not available)

For Dusty Applications D-100WA D-100SWA



Dimensions (D-50 / D-50S / D-50HT)

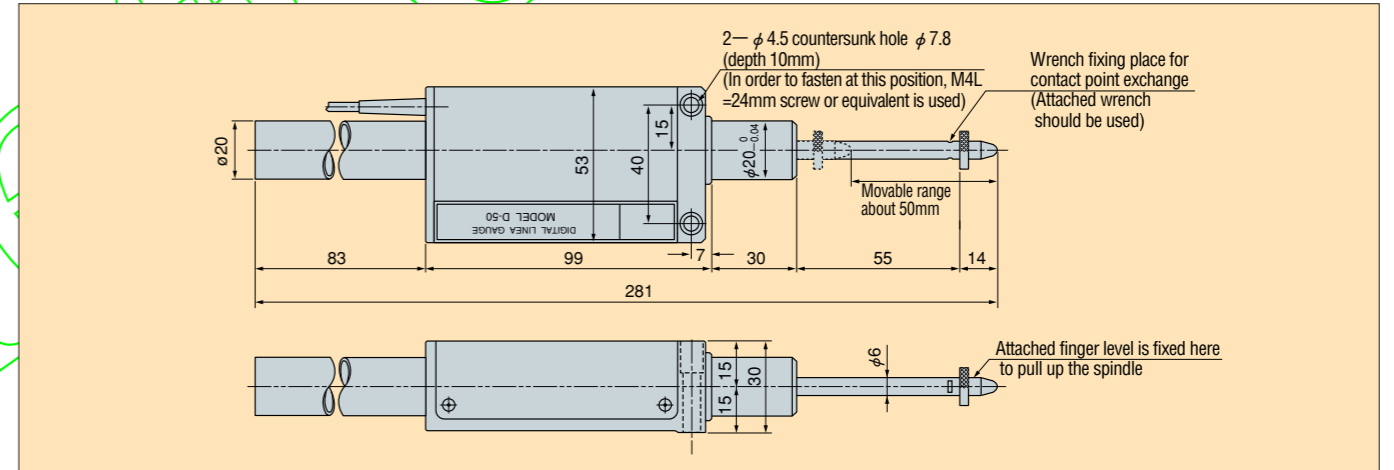

Dimensions (D-100 / D-100S)

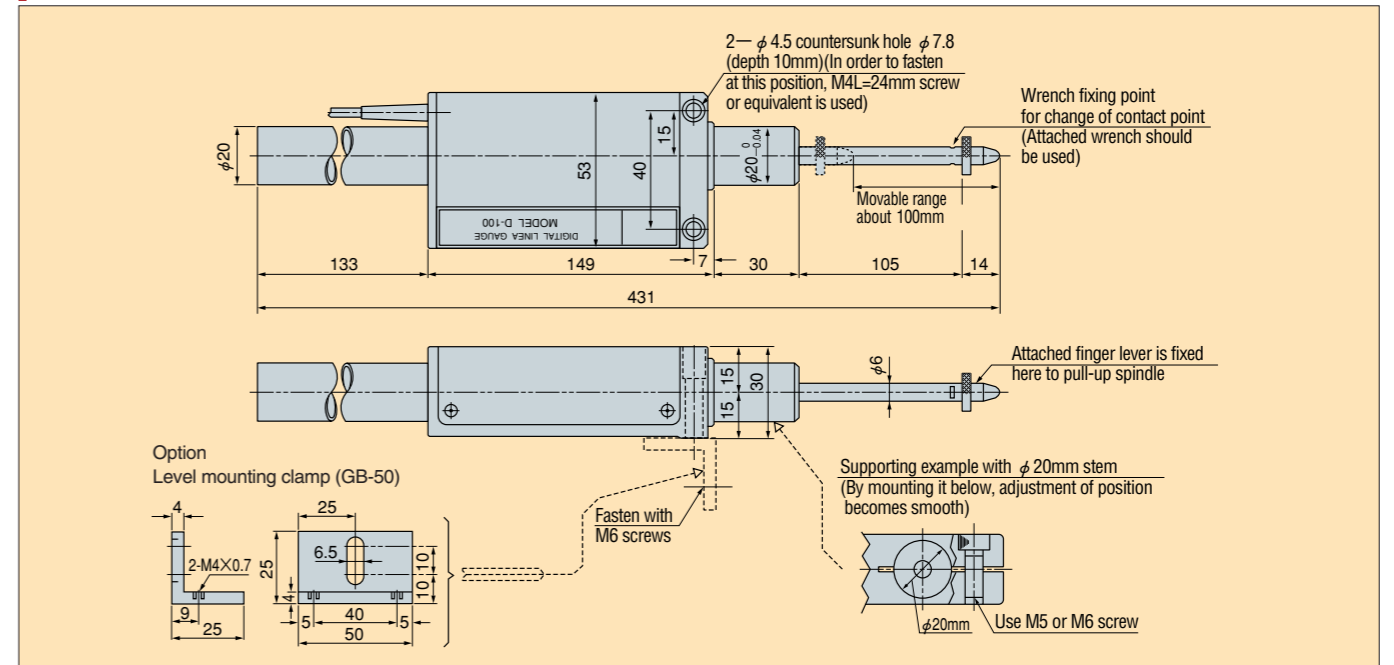

11 High Resolution Type 0.1μm and 0.5μm

- Use of linear scale improves accuracy and reduces error due temperature influences.



D-10SS
Resolution: 0.0005mm(0.5μm)
Range: 0-10mm

D-10HS
Resolution: 0.0001mm(0.1μm)
Range: 0-10mm
● With spindle pull-up back lever

Specifications

Model	D - 10SS	D - 10HS
Range	10mm	10mm
Resolution	0.0005mm	0.0001mm
Accuracy (excluding quantized error)	0.001mm	0.0005mm
Measuring force	Less than 1.0N	
Cable length	2m	
Operating temperature	0-40°C	
Contact point	M2.5 X 0.45 S φ 2.4mm steel (X-2)	M2.5 X 0.45 S φ 2.4mm steel (X-2)
Mounting method	φ 8mm stem or back cover with lug (φ 6.5mm hole)	φ 8mm (no provision for back cover with lug mounting)
Weight	220g	200g
Output signal	90° phase difference, 8μm pitch (R03-PB8M Tajimi connector)	90° phase difference, 8μm pitch (approximate Sinusoidal wave) (R03-PB8M Tajimi connector)
Compatible standard counters	C-7HS	
Accessories	<ul style="list-style-type: none"> ● Release (RE-4) ● Back cover with lug (GB-1DX) 	Spindle pull-up back lever (exclusively for D-10HS)
Options	<ul style="list-style-type: none"> ● Accuracy list ● Parallel adjustment Contact point (X-10) ● Gauge stand (PDS-2) 	X-10 When using 'Flat' contact point, choose contact point which has parallel adjustment in relation to anvil surfaces as shown in picture.

Dimensions (D-10HS)

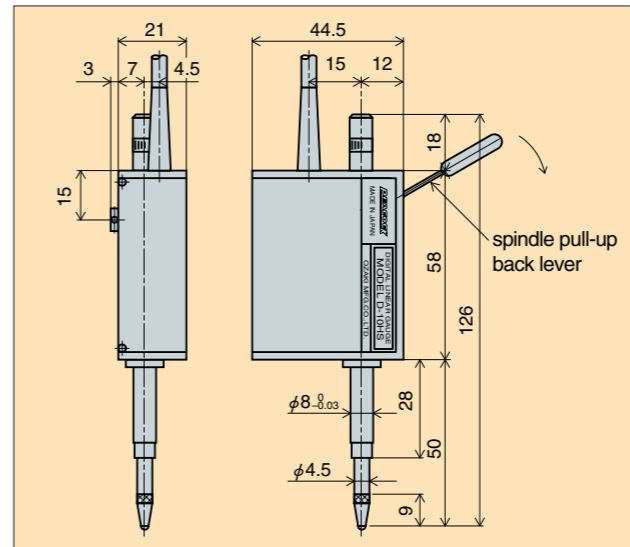

Extension cables for Linear Gauges

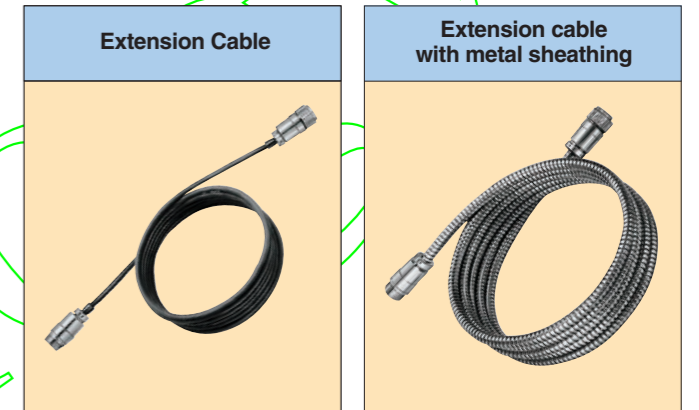

2, 3, 5 and 10 meters are standard length. 2 and 3 meters are standard length.

Common Specifications of Linear Gauges

Items	Common specifications
Type of gauges	DL-2S, D-5S, D-10S, D-20S, D-50S, D-100S DL-2, D-5, D-10, D-20, D-50, D-100, D-5UZ
Displacement transducer type	Glass linear scale (scale pitch 20μm) (D-10SS·D-10HS: pitch 8μm)
Power supply	+12DCV ±5% (consumed current 40mA)
Signal cable length	2m (2,3,5 and 10m extension cables are available) 4 core shield cable & oil proof type
Output connector, Receiver connector	Gauge side (R03-PB8M) Counter side (R03-R8F) Tajimi connectors
Output signal (A) 1μm resolution	2 phase signal with 90° phase difference, 20μm pitch, sinusoidal wave-form
Output signal (B) 5μm/10μm resolution	2 phase signal with 90° phase difference, 20μm pitch, approximate sinusoidal wave-form
Output signal (C) 5μm/10μm resolution	2 phase signal with 90° phase difference, 20μm pitch, square wave-form (gauges: DN-10, DN-20)
Output signal (D) 0.5μm/0.1μm resolution	2 phase signal with 90° phase difference, 8μm pitch, sinusoidal wave-form (gauges: D-10SS, D-10HS)
Operating temperature	0-40°C (except for high temperature type)
Output Frequency	0-50KHz
Contact point	M2.5 x 0.45 (contact points for dial gauge can be used)

Output signal (A) wave-form (1μm resolution)

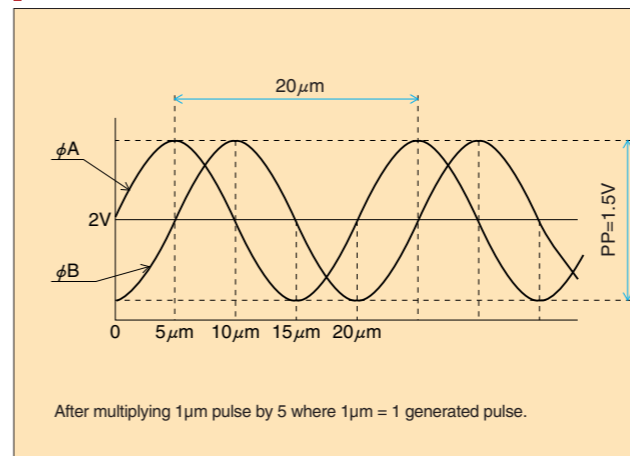

Signal Connector R03-PB8M (manufactured by Tajimi)

Pin arrangement

Pin No.	Signal	Wire Color
A	GND	black
B	φ A	blue
C	+12V	red
D	φ B	white
E	NC	unused
F	shielded wire (FG)	
G	NC	unused
H	NC	unused

Digital Counters

New Type

Equipped with large display functions and various measurement functions, our Digital Counters can be installed in a Control Panel or placed on a desk due to their compact designs.



Simple type
Priority on user friendliness.
C-500



Multi-type
User friendliness combined with multi-functionality.
C-700

1/2 Display (C-500/C-700)

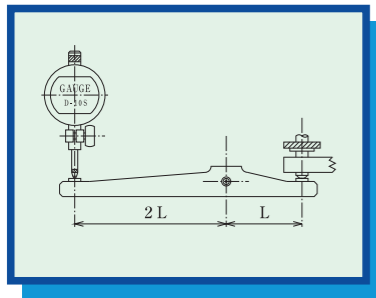

Displays the displacement after halving it.

×2 Display (C-500/C-700)

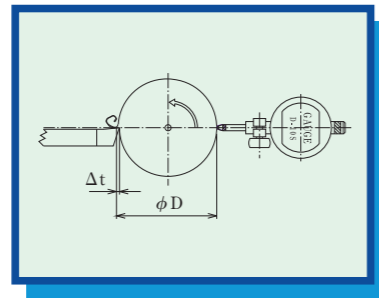

Displays the displacement after doubling it.

Inch Display (C-500/C-700)

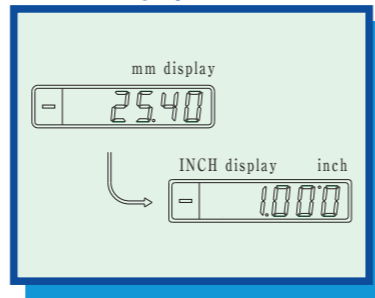

Displays the displacement in terms of inches.

Data Output (C-500/C-700)

(Standard function of RS-232C, optional function of BCD)

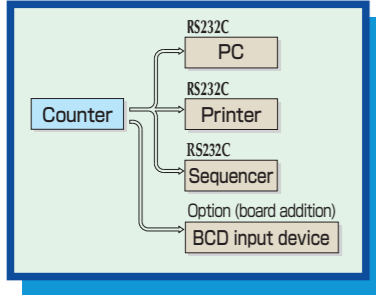

Outputs data

Presetting (C-700)

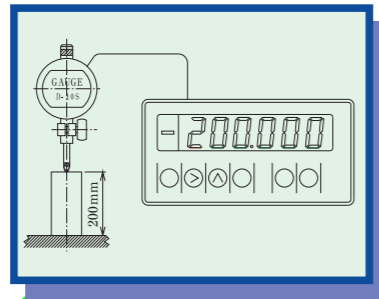

Displays preset values.

OK±NG Judgment (C-700)

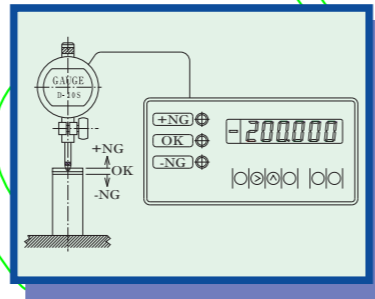

Outputs OK±NG judgment.

Maximum Value Display (C-700)

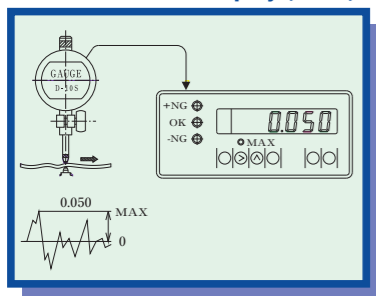

Holds the maximum positive value and makes OK±NG judgment.

Minimum Value Display (C-700)

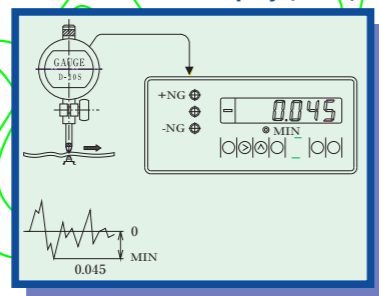

Holds the minimum negative and makes OK±NG judgment.

Deflection Measurement Display (C-700)

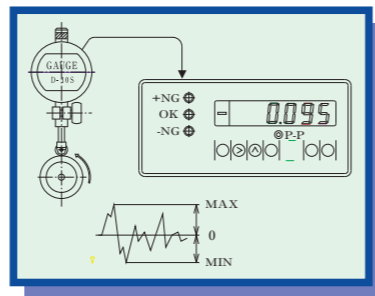

Holds the difference between the maximum and minimum values (deflection) and makes OK±NG judgment.

Specifications of Digital Counters

Model	Model No. C-500	Model No. C-700																															
Displayed digits	* Selection of 10 μm * Selection of 1 μm	—9999.99~00.00~9999.99 —999.999~0.000~999.999																															
Display	High-luminance LED display with 7segments (red)																																
Power supply voltage & power consumption	AC100V~AC240V · 9VA or lower																																
Operating temperature	0~+40°C																																
Compatible Linear Gauges	DL-2 D-5 D-10 D-20 D-30 D-50 D-100 DN-10 DN-20 D-5UZ DL-2S D-5S D-10S D-20S D-30S D-50S D-100S DN-10S DN-20S																																
Accessories	<ul style="list-style-type: none"> ◆AC power cord (2m): One cord ◆Metal fittings for panel installation: Two units (to be used for installation in panel and securing stand fittings) ◆Stand fittings: One unit (to be used when counter is used as desktop device) 																																
Terminal block functions (Rear panel)	<ul style="list-style-type: none"> ◆Terminal block: Screwless terminal block ◆Usable electric cables: AWG22-28 ◆Length of peeled wire of cables: 8~9mm ◆Pin alignment <table border="1"> <tr> <td>*1</td> <td>St/Sp</td> <td>Controls "START" and "STOP" of MAX, MIN, P-P measurement mode.</td> </tr> <tr> <td>*2</td> <td>React</td> <td>Controls "SUSPEND" and "START" of P-P measurement mode.</td> </tr> <tr> <td>3</td> <td>Latch</td> <td>Controls "LATCH" and "CANCEL" of measured value.</td> </tr> <tr> <td>4</td> <td>Reset</td> <td>External "RESET" "PRESET" (Function available only in Model No. C-700)</td> </tr> <tr> <td>5</td> <td>Alarm</td> <td>Error signal output</td> </tr> </table> <table border="1"> <tr> <td></td> <td>Max Display</td> <td>Min Display</td> <td>P-P Display</td> </tr> <tr> <td>*6</td> <td>+NG (2)</td> <td>-NG (1)</td> <td>NG (2)</td> </tr> <tr> <td>*7</td> <td>OK</td> <td>OK</td> <td>OK</td> </tr> <tr> <td>*8</td> <td>+NG (1)</td> <td>-NG (2)</td> <td>NG (1)</td> </tr> </table> <p>(1):NG output in first stage (2):NG output in second stage</p> <p>* marked numbers indicate functions available only in Model No.C-700</p>		*1	St/Sp	Controls "START" and "STOP" of MAX, MIN, P-P measurement mode.	*2	React	Controls "SUSPEND" and "START" of P-P measurement mode.	3	Latch	Controls "LATCH" and "CANCEL" of measured value.	4	Reset	External "RESET" "PRESET" (Function available only in Model No. C-700)	5	Alarm	Error signal output		Max Display	Min Display	P-P Display	*6	+NG (2)	-NG (1)	NG (2)	*7	OK	OK	OK	*8	+NG (1)	-NG (2)	NG (1)
*1	St/Sp	Controls "START" and "STOP" of MAX, MIN, P-P measurement mode.																															
*2	React	Controls "SUSPEND" and "START" of P-P measurement mode.																															
3	Latch	Controls "LATCH" and "CANCEL" of measured value.																															
4	Reset	External "RESET" "PRESET" (Function available only in Model No. C-700)																															
5	Alarm	Error signal output																															
	Max Display	Min Display	P-P Display																														
*6	+NG (2)	-NG (1)	NG (2)																														
*7	OK	OK	OK																														
*8	+NG (1)	-NG (2)	NG (1)																														
Dip sw setting functions (Printed circuit board)	<table border="1"> <tr> <td colspan="2">Dip (1)</td> <td colspan="2">Dip (2)</td> </tr> <tr> <td>SW 1</td> <td>Select 1 μm or 10 μm</td> <td>SW 1</td> <td>Settings by Manufacturer</td> </tr> <tr> <td>SW 2</td> <td>Select direction of counting.</td> <td>SW 2</td> <td>Select whether or not to include default values for OK ±NG judgment.</td> </tr> <tr> <td>SW 3</td> <td>Select activation or non activation of error output.</td> <td>SW 3</td> <td>Select either "orthogonal" or "sine" for input waveform.</td> </tr> <tr> <td>SW 4</td> <td>Select activation or non activation of overflow.</td> <td>SW 4</td> <td>Select either 400msec or 100msec for RESET time.</td> </tr> </table>		Dip (1)		Dip (2)		SW 1	Select 1 μm or 10 μm	SW 1	Settings by Manufacturer	SW 2	Select direction of counting.	SW 2	Select whether or not to include default values for OK ±NG judgment.	SW 3	Select activation or non activation of error output.	SW 3	Select either "orthogonal" or "sine" for input waveform.	SW 4	Select activation or non activation of overflow.	SW 4	Select either 400msec or 100msec for RESET time.											
Dip (1)		Dip (2)																															
SW 1	Select 1 μm or 10 μm	SW 1	Settings by Manufacturer																														
SW 2	Select direction of counting.	SW 2	Select whether or not to include default values for OK ±NG judgment.																														
SW 3	Select activation or non activation of error output.	SW 3	Select either "orthogonal" or "sine" for input waveform.																														
SW 4	Select activation or non activation of overflow.	SW 4	Select either 400msec or 100msec for RESET time.																														
Data output (RS-232C) D-Sub9P plug INCH screw	<ul style="list-style-type: none"> ◆Pin Alignment <table border="1"> <tr> <td>1</td> <td>NC</td> <td>—</td> </tr> <tr> <td>2</td> <td>Rxd</td> <td>in←</td> </tr> <tr> <td>3</td> <td>Txd</td> <td>→out</td> </tr> <tr> <td>4</td> <td>NC</td> <td>—</td> </tr> <tr> <td>5</td> <td>SG</td> <td>—</td> </tr> <tr> <td>6</td> <td>NC</td> <td>—</td> </tr> <tr> <td>7</td> <td>RTS</td> <td>→out</td> </tr> <tr> <td>8</td> <td>CTS</td> <td>in←</td> </tr> <tr> <td>9</td> <td>NC</td> <td>—</td> </tr> </table> <ul style="list-style-type: none"> ◆Communication mode: Half-duplex asynchronous communication ◆Communication speed: 9600bps ◆Format: 7Bit ASCII ◆Parity: even number ◆Stop bit: 1Bit ◆RTS/CTS: Returned when not in use. ◆Reception command: Transmission request ASCII [T] [t] : Reset ASCII [R] [r] ◆Connection cables: Cross cables (not included) 		1	NC	—	2	Rxd	in←	3	Txd	→out	4	NC	—	5	SG	—	6	NC	—	7	RTS	→out	8	CTS	in←	9	NC	—				
1	NC	—																															
2	Rxd	in←																															
3	Txd	→out																															
4	NC	—																															
5	SG	—																															
6	NC	—																															
7	RTS	→out																															
8	CTS	in←																															
9	NC	—																															
Options	<ul style="list-style-type: none"> * BCD output board ◆CB-BCD Can not be used in combination with RS-232C output. 																																
Display functions	<ul style="list-style-type: none"> ◆1/1 display: Displays the measured value as is. ◆1/2 display: Displays the measured value after halving it. ◆×2 display: Displays the measured value after doubling it. ◆INCH display: Displays the value after converting it into inches. <p>Note: With 1 μm display and ×2 display, the lowest digit will be displayed as an even number.</p>																																
Presetting display function	◆Zero setting only	◆Can display preset values																															
Measurement mode function [MAX] [MIN] [P-P]		<ul style="list-style-type: none"> ◆Current value display ◆Maximum value(Max) ◆Minimum value(Min) ◆Deflection(P-P) <p>RESET action is taken by ST of the ST/SP control terminal.</p>																															
OK±NG judgment function (Refer to terminal output circuit)		<ul style="list-style-type: none"> ◆Current value mode: +NG OK -NG ◆Maximum value mode: OK +NG(1) +NG(2) ◆Minimum value mode: OK -NG(1) -NG(2) ◆Deflection mode: OK NG(1) NG(2) 																															
Dimensions & weight	◆144(W)×72(H)×160(D)mm	◆950g																															

Time Chart [Model No.C-700]

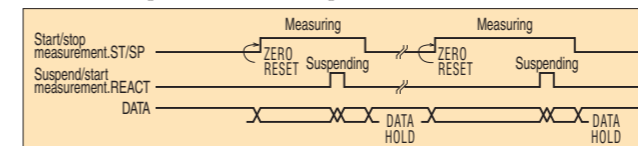

Control Terminal Input Circuit

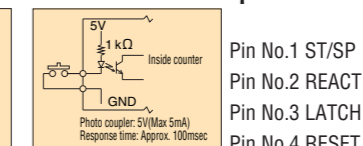

Terminal Output Circuit

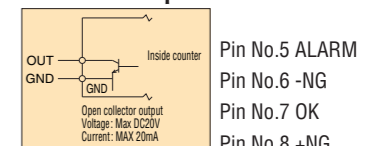

11 with High Resolution

- Resolution capability of 0.1μm / 0.5μm.
- Recommended for very high precision measurement.



C-7HS
Resolution: 0.0001mm (0.1μm) / 0.0005mm (0.5μm)

Specifications

Model	C-7HS
Resolution	0.0001mm (0.1μm) / 0.0005mm (0.5μm) Please specify either 0.0005mm or 0.0001mm display at the time of purchase.
Display	6 digits display with ± sign ±99.9999
Response speed	100mm / sec
Weight	2.6kg
Display	Green fluorescent light display
Power supply	AC100V~AC240V (90~100V) 50/60Hz
Dimensions	200 (W) × 230 (D) × 60 (H) mm
Operating temperature	0 to 40°C / storage, at -5 to 50°C
Compatible linear gauges	0.0001mm : D-10HS / 0.0005mm : D-10SS
Accessories	● Built-in tilt stand (tilts the front of the counter up at slight angle for easier reading)
Functions	<ul style="list-style-type: none"> ● RESET.....For zero reset at any desired position ● DIRECTION.....Numerical direction can be changed by DIRECTION switch located on back panel ● CLOCK OUT..... Outputs BCD's signal simultaneously (1μsec) ● ALARM OUT..... Output abnormal value when response speed is exceeded ● LATCH IN..... Holds the display value and external output data ● RESET IN..... For zero reset from external unit via its RESET input
Data output (RS-232C/BCD OUT)	<ul style="list-style-type: none"> ● Output by positive logic, parallel digits and open collector ● Connector..... 57-40360 DDK equivalent connector (amphenol type) should be used. It is not attached on the cable side. (57-30360 equivalent connector is recommended)
Options	<ul style="list-style-type: none"> ● Printer (PDP-1N)..... Statistic operation ● External RESET / LATCH function: C-7HS-RL.

11 with Judgement Function

- Equipped with Judgement function OK, ±NG (No Go).
- Either 10μm or 1μm resolution setting can be selected.
- 2X or 1/2 X Display magnification.



CM-5B
Resolution: 0.005mm / 0.001mm convertible

Specifications

Model	CM-5B				
Resolution	0.005mm or 0.001mm select by conversion switch				
Display capacity	For 0.005mm, 0 ~ ±199.995mm For 0.001mm, 0 ~ ±199.999mm				
Judgement setting display	Lower and Upper limit setting via digital switch of 6 digits each				
Response speed	1000mm / sec at 0.005mm setting 600mm / sec at 0.001mm setting				
Quantizing error	±1 count				
Judgement Output	Output from relay contact point (a contact point) (DS1-S-DC5V Matsushita or equivalent product)				
Judgement Display	-NG (Yellow), OK (Green) & +NG (Red)				
Operating temperature	0 to 40°C / for storage, at -10 to 50°C				
Power supply	AC100V~AC240V (90V ~ 110V) 50/60Hz				
Weight / Dimensions	2.2kg 200 (W) × 230 (D) × 70 (H) mm				
Functions	<ul style="list-style-type: none"> ● User selectable resolution (0.001mm at time of shipment). ● Equipped with failure alarms (When counting error or gauge fails, display blinks) ● Judgement output is constantly on (control output is possible with an additional optional connector) ● Setting values for judgement is included in ±NG at shipment (Changeable) ● BCD output can be connected to, for example, a sequencer by using open collector. 				
Data output (RS-232C/BCD OUT)	<ul style="list-style-type: none"> ● Output by positive logic, parallel digits and open collector ● Connector..... 57-40360 DDK equivalent connector should be used. It is not attached on the cable side. 				
Compatible linear gauges	<table border="1"> <thead> <tr> <th>At 0.005mm setting</th> <th>At 0.001mm setting</th> </tr> </thead> <tbody> <tr> <td>DL-2, D-5, D-10, D-20, D-50, D-100, D-5UZ, DN-10, DN-20</td> <td>DL-2S, D-5S, D-10S, D-20S, D-50S, D-100S</td> </tr> </tbody> </table>	At 0.005mm setting	At 0.001mm setting	DL-2, D-5, D-10, D-20, D-50, D-100, D-5UZ, DN-10, DN-20	DL-2S, D-5S, D-10S, D-20S, D-50S, D-100S
At 0.005mm setting	At 0.001mm setting				
DL-2, D-5, D-10, D-20, D-50, D-100, D-5UZ, DN-10, DN-20	DL-2S, D-5S, D-10S, D-20S, D-50S, D-100S				
Accessories	● Judgement output connector 1 pc. (PRC03-12A10-4F10.5 Tajimi brand)				
Options	<ul style="list-style-type: none"> ● Additional pass / fail detection control connector (attachable to the back panel). Includes CM-5B-CONT. ● External RESET / LATCH connector is added (on back panel). CM-5B-RL. ● Tilt stand is added (for tilting display for easy viewing). CM-5B-ST. 				
Mounting Precaution	When mounting into rack requires the removal of bottom rubber support, screws must be applied at regular intervals. (Avoid screws penetration into body as damage to printed circuit board is high)				

data

Printer

11

- Printing of statistically processed data is vital for quality management.
- Input of date and time via front control panel data keys for quality assurance data purposes.
- Items for statistic operation maybe selected from Mode 0 to 1



Specifications

Description			
Number of channels	1		
Maximum no. of date	99		
Printing method	Dot matrix graphic		
Recording paper	Roll (38mm wide X 28mm dia.)		
Power supply	AC adapter (AC100V~AC240V 50/60Hz)		
Operating temperature	0~40°C		
Outer dimensions	130 (W) X 170 (D) X 61 (H) mm		
Weight	1 kg		
Accessories	<ul style="list-style-type: none"> ● Recording paper.....1 roll ● AC adapter.....1 pc 		
Options	<ul style="list-style-type: none"> ● Foot switch (FW-1) ● Connecting cable (for signal input) 		
Method of date input	BCD positive logic parallel/serial RS-232C port		
Print-out and calculation categories	<table border="0"> <tr> <td> <ul style="list-style-type: none"> Ⓐ Measuring date Ⓐ Each data Ⓐ Max data Ⓐ Min data Ⓐ Range (R) Ⓑ Defect rate (BAD) Ⓑ Frequency distribution table Ⓑ Diagram </td> <td> <ul style="list-style-type: none"> Ⓐ Number indicating measured data Ⓐ Number of measured data (n) Ⓐ Mean value (X) Ⓐ Standard deviation (σ) Ⓑ Process capability index (Cp) Ⓑ Printing in red for abnormal value Ⓑ Histogram </td> </tr> </table>	<ul style="list-style-type: none"> Ⓐ Measuring date Ⓐ Each data Ⓐ Max data Ⓐ Min data Ⓐ Range (R) Ⓑ Defect rate (BAD) Ⓑ Frequency distribution table Ⓑ Diagram 	<ul style="list-style-type: none"> Ⓐ Number indicating measured data Ⓐ Number of measured data (n) Ⓐ Mean value (X) Ⓐ Standard deviation (σ) Ⓑ Process capability index (Cp) Ⓑ Printing in red for abnormal value Ⓑ Histogram
<ul style="list-style-type: none"> Ⓐ Measuring date Ⓐ Each data Ⓐ Max data Ⓐ Min data Ⓐ Range (R) Ⓑ Defect rate (BAD) Ⓑ Frequency distribution table Ⓑ Diagram 	<ul style="list-style-type: none"> Ⓐ Number indicating measured data Ⓐ Number of measured data (n) Ⓐ Mean value (X) Ⓐ Standard deviation (σ) Ⓑ Process capability index (Cp) Ⓑ Printing in red for abnormal value Ⓑ Histogram 		
Function of print-out according to mode	MODE-0.....Operation printing of Ⓐ items MODE-1.....Operation printing of Ⓐ to Ⓑ		

Discontinued

Connecting cable selection list

Model	Applicable measuring equipment or device
KB-C12	C-7HS
KB-C232	C-700 C-500
KB-CM12	CM-5B
KB-P12	PDN-21 PDN-51
KB-C205 (with connector)	DG-127 DG-205 DG-257

Applied Digital Indicators

11

Digital Thickness Gauges (0.01mm, 0.001mm)

- The thickness of small parts etc. can be quickly measured by lever operation.
- Contact Point and Anvil can be modified made to order.



G2-205 · G2-257 · G2-127

Resolution and Range
(0.001×20mm) · (0.01×20mm) · (0.01×10mm)

G2-205M · G2-257M · G2-127M

Resolution and Range
(0.001×20mm) · (0.01×20mm) · (0.01×10mm)

G2-205A · G2-257A · G2-127A

Resolution and Range
(0.001×20mm) · (0.01×20mm) · (0.01×10mm)

Dimensions

G2-205 · G2-257 · G2-127

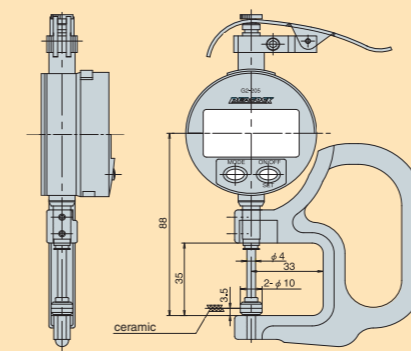

G2-205M · G2-257M · G2-127M

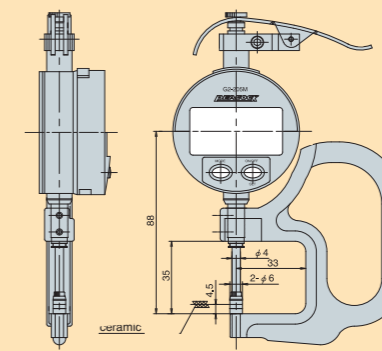

G2-205A · G2-257A · G2-127A

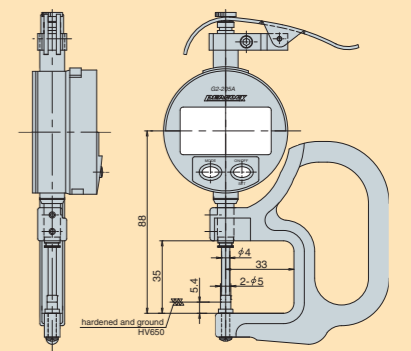

Specifications

Model	Resolution (mm)	Accuracy (excluding quantized error) (mm)	Gauge type	Measuring range (mm)	Measuring depth (mm)	Measuring force (N)	Contact point diameter (mm)	Contact point parallelism (mm)	Anvil diameter (mm)
G2-205	0.001	±0.008	DG-205	20	33	Less than 1.1	ø10	Less than 0.005	ø10
G2-257	0.01	±0.02	DG-257	20	33	Less than 1.1	ø10	Less than 0.01	ø10
G2-127	0.01	±0.02	DG-127	10	33	Less than 0.95	ø10	Less than 0.01	ø10
G2-205M	0.001	±0.008	DG-205	20	33	Less than 1.1	ø6	Less than 0.005	ø6
G2-257M	0.01	±0.02	DG-257	20	33	Less than 1.1	ø6	Less than 0.01	ø6
G2-127M	0.01	±0.02	DG-127	10	33	Less than 0.95	ø6	Less than 0.01	ø6
G2-205A	0.001	±0.008	DG-205	20	33	Less than 1.1	ø5	Less than 0.005	ø5
G2-257A	0.01	±0.02	DG-257	20	33	Less than 1.1	ø5	Less than 0.01	ø5
G2-127A	0.01	±0.02	DG-127	10	33	Less than 0.95	ø5	Less than 0.01	ø5

Applied Digital Gauges

Digital Thickness Gauges (Large Type), Digital Sheet Gauge

- Due to having throat depth 150mm or 300mm can measure a thickness at the center of wide sheets such as paper, urethane, vinyl, rubber and foil etc.
- Contact Point and Anvil can be modified made to order.

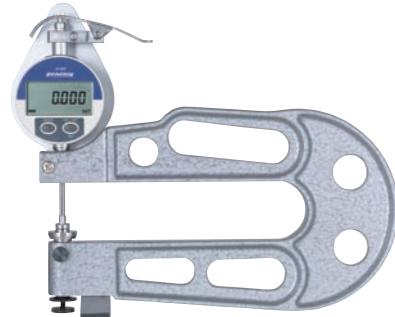

JA-205
Resolution: 0.001mm
Range: 20mm

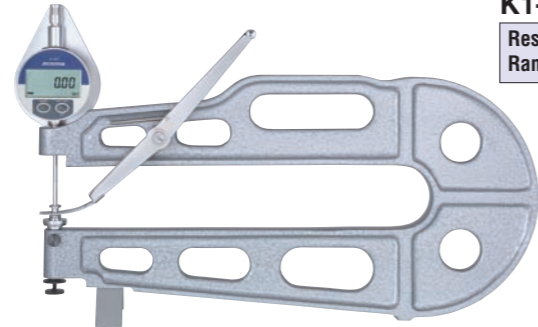

K1-257
Resolution: 0.01mm
Range: 20mm

Dimensions JA-205 · JA-257

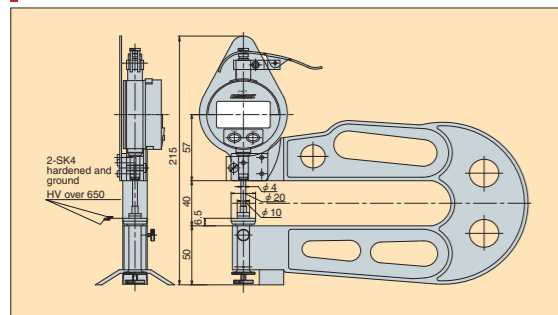

Dimensions K1-257

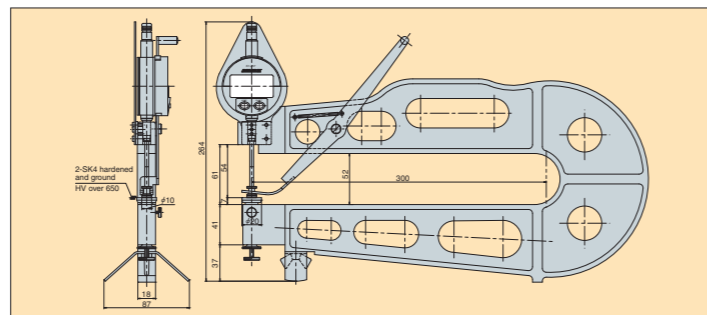

Specifications

Model	Resolution (mm)	Accuracy (excluding quantized error) (mm)	Gauge type	Measuring range (mm)	Measuring depth (mm)	Measuring force (N)	Contact point diameter (mm)	Contact point parallelism (mm)	Anvil diameter (mm)
JA-205	0.001	±0.01	DG-205	20	150	Less than 1.1	ø10	Less than 0.005	ø20
JA-257	0.01	±0.02	DG-257	20	150	Less than 1.1	ø10	Less than 0.01	ø20
K1-257	0.01	±0.02	DG-257	20	300	Less than 2.0	ø10	Less than 0.01	ø20

Digital Pipe Gauge

P2-257

Resolution: 0.01mm
Range: 15mm

P2-127

Resolution: 0.01mm
Range: 10mm



Dimensions

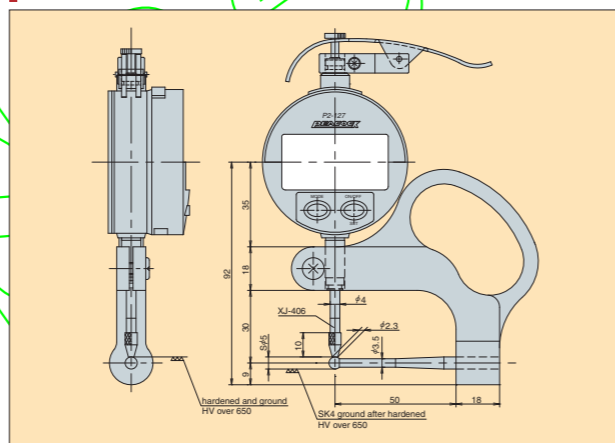

Specifications

Model	Resolution (mm)	Accuracy (excluding quantized error) (mm)	Gauge type	Measuring range (mm)	Measuring depth (mm)	Measuring force (N)	Measuring hole diameter (mm)
P2-257	0.01	±0.02	DG-257	15	50	Less than 1.1	ø5.1
P2-127	0.01	±0.02	DG-127	10	50	Less than 0.95	ø5.1

Applied Digital Gauges

Digital Upright Gauges (0.001mm, 0.01mm)

- Best suited to inspect sizes precision parts or to measure thickness of laboratory specimens.



R1-205
Resolution: 0.001mm
Range: 20mm

R1-257
Resolution: 0.01mm
Range: 20mm

R1-127
Resolution: 0.01mm
Range: 12mm

Contact Point (X-10)

Dimensions

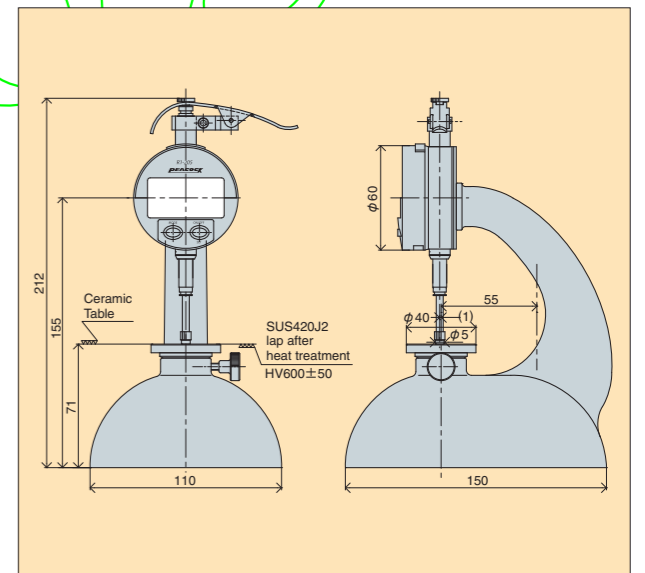

Specifications

Model	Resolution (mm)	Accuracy (excluding quantized error) (mm)	Gauge type	Measuring range (mm)	Measuring force (N)	Measuring depth (mm)	Contact point (mm)	Table diameter (mm)
R1-205	0.001	±0.004	DG-205	20	Less than 1.1	55	ø5	ø40
R1-257	0.01	±0.02	DG-257	20	Less than 1.1	55	ø5	ø40
R1-127	0.01	±0.02	DG-127	12	Less than 0.95	55	ø5	ø40

Modification for contact point (Special order)

Flat type	Replaceable Contact Point	Needle type
<p>Please specify "øD"</p>	<p>Accessories for Dial Gauges Replaceable contact points can be installed.</p>	<p>Please specify dimension of "H" and "øD"</p>

Deep Hole Bore Gauge-EMCC Series

- The EMCC Series can easily measure the inside diameter of deep bore with high accuracy, which has been precision-machined.
- The EMCC Series advances a detector having an automatic alignment mechanism in line with the inside diameter.
- Measurement is possible up to the length of 10M by using an additional extension rod.



Compatible Counter C-500



EMCC-3

Specifications

Model	EMCC-2	EMCC-3	EMCC-4	EMCC-5	EMCC-6		
Measuring range (ID)	35 ~ 60mm	50 ~ 100mm	100 ~ 160mm	160 ~ 250mm	250 ~ 400mm		
Measuring depth	70mm ~ 10M	90mm ~ 10M	120mm ~ 10M	130mm ~ 10M	150mm ~ 10M		
Number of feeler	Intervals 5mm×6	Intervals 5mm×11	Intervals 10mm×7	Intervals 10mm×10	Intervals 10mm×16		
Thickness of washers	1,2,3mm each		1,2,3,4mm each				
Contact Point	L=33mm (flat type)		L=44mm (flat type)				
Contact point's travel and measuring force	1.4mm / less than 2.0N						
Extension rods	EMCC-L (1 meter rod×10 rods = 10 meters)sold separately						
Compatible linear gauges	● When Resolution is 10μm, use D-5B ● When Resolution is 1μm, use D-5SB						
Compatible counters	● C-500						
Operations	● Test completes only after receiving reference from a master and inserting the micrometer head through a workpiece. ● Automatic centering mechanism requires no manual "shaking" to center up the micrometer head.						
Functions	● Workpiece has to be horizontally level (No test can be performed with the workpiece perpendicular).						
Dimensions (mm)	A	70	71	77	77	77	
	B	20	30	40	45	50	
	C	30	40	55	60	70	
	D	62	82	115	125	140	
	E	15	20	38	58	88	
	F	22	30	50	70	100	
	G	MIN	35	50	100	160	250
		MAX	60	100	160	250	400

※ To make up a complete working unit, it requires an EMCC (2-6), an EMCC-L (extension rod set), a linear gauge and a counter.

Dimensions

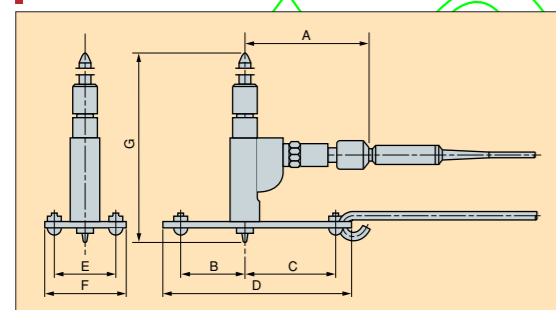

Gauge Sensor

Model	D-5B	D-5SB
Resolution	0.01mm	0.001mm
Accuracy	0.01mm	0.002mm
Cable length	10 meters	
Screw pitch of Contact Point	M2.5 × 0.45	
Measuring force	Less than 0.5N	
Remarks	Specifications are according to D-5S	

Features

- **The inside diameter of extremely deep can be measured. (Max. 10M)**
The inside diameter of the deep hole that was not able to be measured so far can be easily measured with our development of automatic brought to a center position and added to extension rods to the Linear Gauge..
- **High performance**
It is possible to measure with high performance as our Linear gauge is used for the detector. (0.01mm, 0.001mm)
- **Easy operation**
Due to our development of our automatic brought to a center position, the measurement operation is easier than a general inside diameter measuring instruments as only insert the cylinder detector in the hole of measurement work-piece.
- **Efficient measurement**
Since the easy operation, it is efficient of the measurement for an inspection of the mass production.
- **Excellent indication stability**
It is necessary to shakes the general cylinder gauge for reads a minimum measurement. However, our EMCC can get the excellent stability of the indication as only insert the detector to the hole of measurement work-piece.
- **Low measuring force**
The work-piece is not so damaged as the measuring force of contact point is 2.0N compared with a general cylinder gauges (5.0~6.0N)
- **Data record**
Digital counter have the RS-232C output so that the measuring data can be processed.

The main usage

Internal diameter measurement of extremely deep hole
Hydraulic Cylinder, Air Cylinder, Cylinder of Extruder, High accuracy Pipe, Mold for Pipe etc.

Extension Rods (1M x 10 pcs) as Optional

To insert or pull-out the detector to the hole of measurement work-piece.

Display Counter

Data displayed by Digitally
Selection of a resolution (0.01mm or 0.001mm)

*see page 145 for more detailed information

Model No.	C-500
Range of Display	At the 0.01mm Selection -9999.99~00.00~9999.99 At the 0.001mm Selection -999.999~0.000~999.999
Resolution	0.001mm / 0.01mm Selectable
Quantized error	±1 count
Data output	RS-232C
Power supply	AC100V~AC240 · less 9VA
Weight	950g

Measurement figure

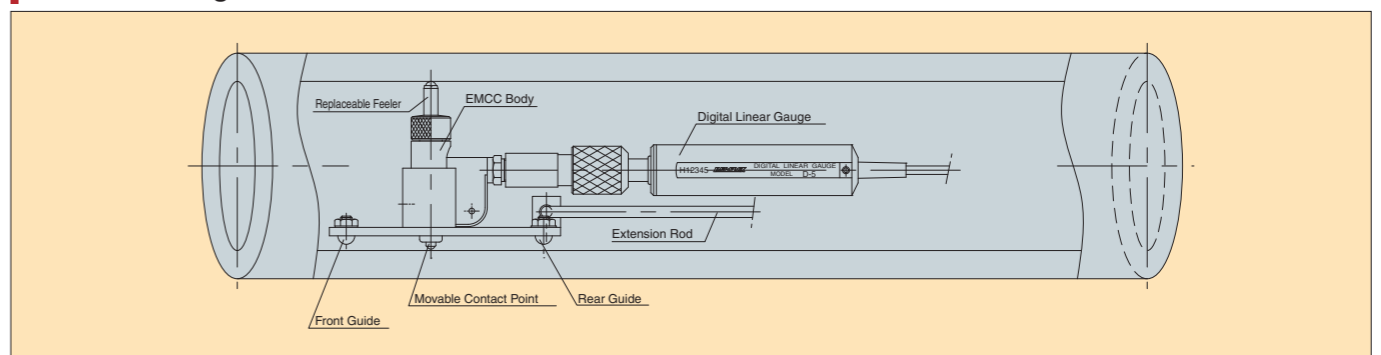

Combination example



- Linear Gauge No. D-50S
- Digital Counter No. C-700
- Gauge Stand No. PDS-2

※As for more detailed specifications, refer to page 117, 140 and 145.

Technical Glossary

● What is a "Linear Scale"?

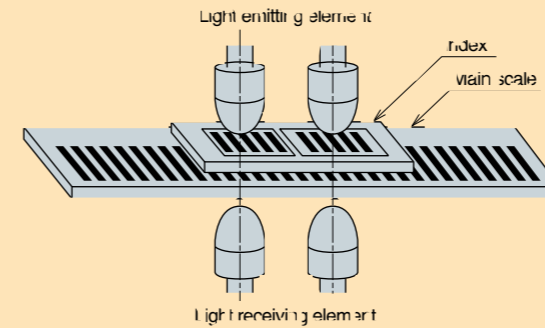

As illustrated on the left, an optical glass with vacuum deposition of chrome metal (opaque) at a constant pitch is called a linear scale (scale pitch of 20, 16 or 8μm is used)

The opposite scale to this linear scale is called an Index scale. This is designed to sense two phases of signal mutually having 90° degree phase difference for the purpose of discriminating shift direction of the scale.

The light intensity of the light emitter is detected by the photo receptor located directly opposite.

When a linear scale moves, the photo receptor will receive variation of light and shade.

Linear displacement can be measured by counting these electric signals with a counter. (Counting them by 20μm pitch will give 5μm display resolution and electrically dividing the wave results in 1μm display resolution)

● About "Quantizing error"

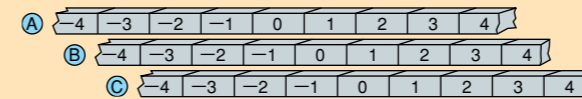

In quantization (displacement under the minimum display digit shall be defined as 0 or 1), the point "0" has a width similar to the other numeric values; including "0" closest to "1" and also "0" closest to "-1". Therefore, ±1 count error is generated in the minimum display digit. (The value "0" is displayed after setting a linear gauge and then pressing the "Reset" switch.)

The counter "C-5" resolves the quantizing error in 1/100mm digit by setting the display value of the minimum digit to 5μm display. (If you need to resolve the quantizing error in 1/1000mm display type, please use "C-5SS" with 0.0005mm display.)

- A's zero reference was taken at the B's zero closer to -1.
- C's zero reference was taken at the B's zero closer to +1

● Difference between "Measuring Force" and "Measuring Pressure"

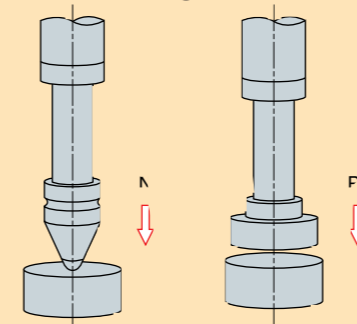

■ "Measuring Force"

Pressure of a contact point pressing a workpiece is defined as measuring force. Generally, as the spindle back spring is integrated in a gauge, it indicates the state in which the spindle is possibly pressed into a workpiece. (A weighted gauge can get a constant measuring force at any position)
Unit:.....N(newton)

■ "Measuring Pressure"

It is the value indicating the force of contact point pressing a workpiece in a unit area. (measuring force per unit layer). After specifying the area (diameter) of contact point to be in contact to a workpiece, the measuring force to be pressed in a unit area is defined as measuring pressure.

(When it is necessary to specify measuring pressure, a type with an attached weight is usually used since there is no change in the measuring force, even in the stroke of a spindle.)

Unit 1Pa = 0.101972 × 10⁻⁵kgf/mm²

● Expression of accuracy

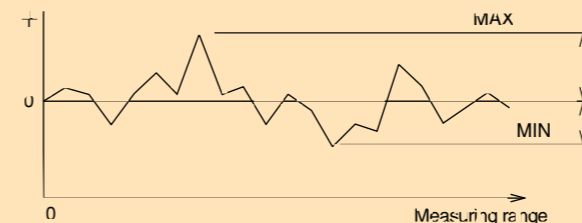

Accuracy is the difference between the zero reference point and the greatest deviation across the entire measurement range. +Xμm represents the combined + error Xμm and - error Xμm allowed.

Xμm represents an absolute value: if an error of Xμm occurs in +, - error is not allowed (0μm). Accordingly, if an error of Xμm occurs in -, + error is not allowed (0μm). Thus, Xμm error allowance is harder to achieve than +Xμm error allowance. (In this catalog, we use absolute value, Xμm.)

■ Accuracy of Lever-type Linear Gauges (DL-2, DL-2S)

These DL-2 and DL-2S linear gauges are used in applications very similar to lever-type dial indicators. Their accuracy is represented every 0.5mm interval, not over the entire measurement range.

- 0~0.5mm 0.5mm~1.0mm
- 1.0~1.5mm 1.5~2.0mm

The entire measurement range is divided into 4 sections. The largest deviation among these 4 sections will determine accuracy.

● Methods of Supporting Stem

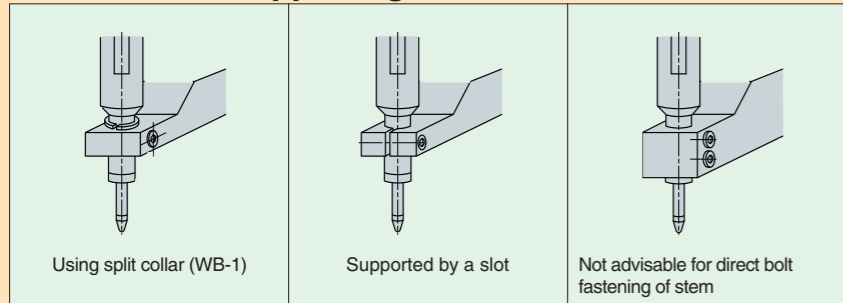

There are 2 methods for mounting of a linear gauge, namely by 'stem' or "lug". As illustrated on the left, please secure a stem by a split collar or a slot. (If a stem is secured directly by a screw or screws, the spindle may not move smoothly.) Please use split collar WB-1 designed exclusively for ϕ 8mm stem.

● Positioning Lever-type Linear Gauges

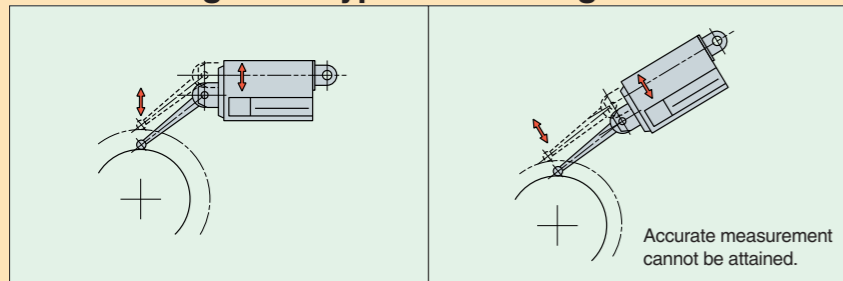

As illustrated on the left for a lever type linear gauge, the lever moves linearly, different from a lever type dial indicator. Lever type dial indicator can be freely set on a workpiece because of its arc movement. However, lever type linear gauge should be set on a workpiece extensively at right angle. (Since no deviation from arc is generated, the measuring range is set to 2mm wide.)

● About Polarity Conversion

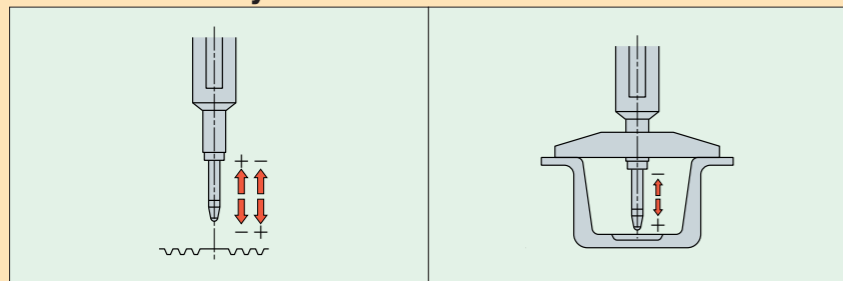

When you need the reversed value to be read, for example, in case of depth measurement, "-" count should be set in the direction of pulling up of a spindle. In standard counters, you will find this switch on the back panel.

● Reset / Preset

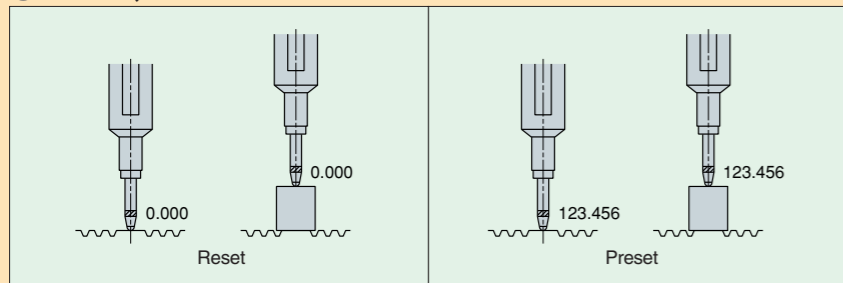

Linear gauges can be reset to zero at any position in the measuring range. Counters with preset function can be set a desired value at a desired position. Since values are displayed based on the preset value as a reference, it is suitable for managing the measured values by their absolute values.

● Protection Classifications

Example of protection classes based on IEC529(DIN40050)(First=protection classes for solid 0 to 6, Second=protection classes for liquid 0 to 8)

IP-54 Protection Class

Type	Class	Specifications
Represents human body, protection and protection against foreign objects	5: Protection against dust	Provides protection against dust.
Represents protection against water	4: Splash proof type	No harmful result caused by water splashed from all directions (water splashproof).

IP-66 Protection Class

Type	Class	Specifications
Represents human body, protection and protection against foreign object	6: Anti-dust seal type	Provides complete anti-dust protection against dust invasion.
Represents protection against water	6: Full waterproof type	Protection that eliminates any water invasion including direct water jet from all directions (completely waterproof).

Metrology